

# AMSTRAD

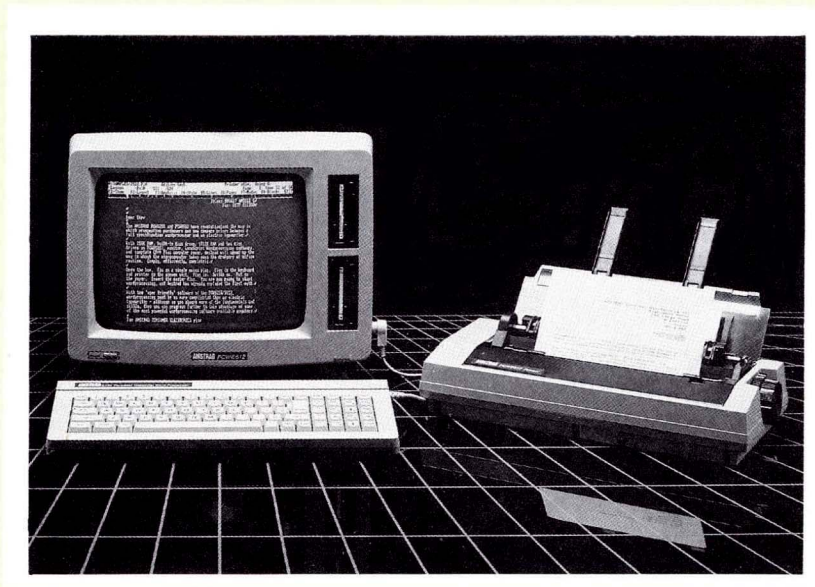

## PCW 8256/8512 PERSONAL COMPUTER WORD PROCESSOR SERVICE MANUAL

Price: £8.00

## SAFETY TEST

**Please note: When any work is carried out on a recorder, the following safety tests must be carried out to ensure continued electrical safety.**

### 1). Flash Test

**Test at 4kV between the live and neutral of the mains lead joined together and ALL accessible metal points on the exterior of the recorder.**

### 2). Insulation Resistance Test

**Test between the live and neutral of the mains lead joined together and ALL accessible metal points on the exterior of the set to show a resistance of at least 4Mohm**

## Specification

### General

The PCW8256 is a completely self contained word processing system including a high performance combined letter quality/high speed draft quality printer, monitor, disc drive, computer and custom word processing software. Additionally, the PCW8256 is supplied complete with the latest implementation of the world's most widely used 8-bit computer operating system, CP/M Plus with GSX graphics enhancement. Locomotive Software's Mallard extended BASIC interpreter (featuring Jetsam record management and double precision arithmetic) is provided to operate under CP/M Plus, along with the educational and training language, Dr LOGO.

### Technical

#### Screen

High Resolution Green Monitor, featuring 90 columns, and 32 lines of text, providing 50% more information area than available on standard 80 x 24 screen displays.

#### Disc

An integral "flip over" 3" disc including AMSTRAD established CP/M standards, offering 180K of formatted storage space per side. A second drive may be fitted optionally.

#### Keyboard and software

An 82 key keyboard is provided with several function keys dedicated to the word processing software provided with the system. The keyboard is controlled by its own custom microprocessor enabling a simple curly-cord connection to the main computer/display unit.

The word processing software supplied has been specifically written to provide all the features and facilities expected on a professional stand-alone word processing system — but using logical and carefully devised procedures that will be readily understood by even the novice computer user.

The word processing software allows for the creation of documents up to the maximum available disc capacity, and will permit simultaneous printing and editing. Features such as pagination, automatic paragraph alignment and re-alignment are provided, together with a powerful collection of editing features for cut/paste etc. The large area screen includes a series of pull down menus accessed by simple function key selections which control all main edit and text format commands.

Under CP/M control, a wide range of standard software including products such as Supercalc, Multiplan, Cardbox etc. will run immediately using the VT52 terminal emulation provided with the CP/M Plus VDU system.

The Digital Research GSX graphic system is supplied with the PCW8256 to provide a standard software interface for graphics output programs. Dr LOGO is also supplied, and is compatible with Dr LOGO supplied for the CPC6128, and upwards compatible with Dr LOGO supplied with AMSTRAD CP/M 2.2 systems.

### CPU and RAM

A Z80A microprocessor with 256K bytes of RAM is provided as standard. Approximately 112K of this memory is organised for use as RAM disc to enhance the speed of operation of the many CP/M programs using overlay techniques. Instead of accessing the disc drive to locate program information not stored in the main memory, this technique uses a much faster semiconductor RAM disc and thus maintains complete compatibility with the vast range of existing CP/M software.

Separate custom microprocessors are used to control the printer and the keyboard.

### Printer

The integral printer mechanism provides letter quality operation at approximately 20 cps, or draft quality text at 90 cps (Elite pitch typestyle). Features such as pitch, italics, boldface, underline, subscript and superscript are provided by the built-in software.

A tractor feed is supplied for continuous stationery, while single sheet operation is available with an automatic paper alignment system.

### Options

An optional RS232C Serial and Centronics Parallel interface (CPS 8256) may be fitted if required.

Specification as PCW8256 but with the second disc drive (1 Megabyte unformatted) fitted as standard and 512K bytes of RAM giving 368K of RAM disc.

### Notes

The term CP/M Plus is synonymous with CP/M3.0.

Either side of an AMSTRAD CP/M Plus or AMSDOS disc may be accessed by the disc controller, depending on which way round the disc is inserted.

Please note that whilst every care has been taken to ensure compatibility with existing CP/M software, some packages available make use of undocumented features of the CP/M operating system, and these may not be supported by the PCW8256/8512 implementation.

In keeping with our policy of continually improving our service, and the technical quality of our products, we reserve the right to change component types, manufacturers, sources of supply or technical specification at any time.

*Keyboard/computer unit, Green Monitor — Designed in U.K., made in Korea.*

*Software — Written in U.K. and U.S.A, made in Korea and U.K.*

*CP/M Plus, CP/M and Dr LOGO are trade marks of Digital Research Inc. IBM and IBM PC are trade marks of International Business Machines Inc.*

*AMSTRAD, AMSOFT, AMSDOS, CPC464, CPC664, CPC6128, PCW8256 and PCW8512 are trade marks of Amstrad Consumer Electronics PLC.*

## IMPORTANT NOTES TO SERVICE ENGINEERS

This Service Manual gives indepth technical information on all of the circuits and the P.C.B.'s which make up the PCW 8256/8512. Much of this data is for information purposes only as the procedure engineers will follow when servicing this equipment will often be to exchange Printed Circuit Boards. In some instances Amstrad will insist that subassemblies are returned for exchange and should not be serviced by Service Engineers.

Please take note of the following information before attempting to service the equipment.

1. Full diagnostics are not specified in this manual. A diagnostic tool, designated the R.P.3., is available from Amstrad and gives certain diagnostic information on the Computer. To carry out any indepth fault-finding this diagnostic tool is necessary.
2. The Disc Drive Mechanism and accompanying Printed Circuit Boards should not be serviced by Service Engineers. Exchange mechanisms complete with P.C.B.'s are available from Amstrad.
3. Information is given on the parts for the Printer Mechanism but complete Printer Assemblies are available on an exchange basis and under normal circumstances, unless the problems are fairly straight forward, you should arrange for an exchange Printer Mechanism.
4. Complete Printed Circuit Boards are available on an exchange basis and unless the Service Engineer is particularly familiar with this product arrangements should be made to exchange the P.C.B.'s where a fault has developed. The R.P.3. diagnostic referred to above can be used to ensure correct diagnosis of the P.C.B. fault.
5. In some instances a second Disc Drive will be fitted to the PCW 8256/8512. This second Disc Drive is subject to seperate service information but under no circumstances should any service work be carried out on the mechanism or its Printed Circuit Board. In the event of a fault on the second Disc Drive arrangements should be made to exchange this.
6. Service Engineers carrying out any repairs on this unit can contact the Technical Advice Section of Amstrad for further information should they have any difficulty.

The PCW 8256/8512 is a sophisticated piece of computer technology and service work should only be undertaken on this equipment by suitably qualified personnel and preferably by appointed Amstrad Service Agents.

# Software Errors

If a drive fault is reported the fault may be a software problem. Before investigating the drive please carry out the following checks to ensure it is not a software problem.

## Detection and Correction of "Soft Errors"

Soft errors are usually caused by the following reasons.

- 1) Random external noise of several usec or less.
- 2) Minute off-tracking and shifting of write timing that are not detected during the write operation which may cause the soft error during the read.

To remedy such soft errors, take the following procedures at the controller side.

- 1) Repetitive reading on the track by 10 times or more until the data is restored.
- 2) When the data is not restored by step 1, access the head to the adjacent track in the same direction as move previously, and thereafter return the head to the original track.
- 3) Repeat the step 1.
- 4) If the data is not restored by the above steps, the error cannot be remedied.

## Write Error

When an error is caused during the write operation, the error is usually detected during the next rotation through the read operation called "Write Check".

To correct the error, repeat the write operation again and carry out the Write Check.

If the result is still incorrect even after the write operation is repeated more than 10 times, either the disc or the drive are working incorrectly. To find out the trouble source, carry out the read operations with another track. Should the error still be found, change the disc and repeat the above procedures. Should error still be found, the disc drive should be considered defective. If the error is removed, the original disc must be defective. Discard it.

## Seek Error

- 1) Step motor or step motor drive circuit is defective.
- 2) The torque of the carriage is not correct.

Restoration procedures from the seek error.

Make the re-calibration to the track OO. Then, carry out the re-seek to the original track.

Notes:

- 1) Always ensure the head is clean.
- 2) Index/Sector Factor (Ready Defect)

As the unit has Optional Read Output

It is normally not ready until 2 revolutions are made after the disc insertion.

## Read Error

Most of the errors are "Soft Errors", in such a case the data are restored by following "Detection and Correction of Soft Errors" correction procedure.

# Diagnostic Flow Chart For FD1 & FD2

This chart must be used in conjunction with the Alignment Procedures

This chart is for information only and does not guarantee an exact diagnosis. For warranty purposes any faulty drive mechanism must be returned to Amstrad for replacement. Service Agents should not attempt any repairs on the mechanism or to its P.C.B. P.No. 30001/30002 or Z.70296.

Information within the brackets is only for FD2.

3-A

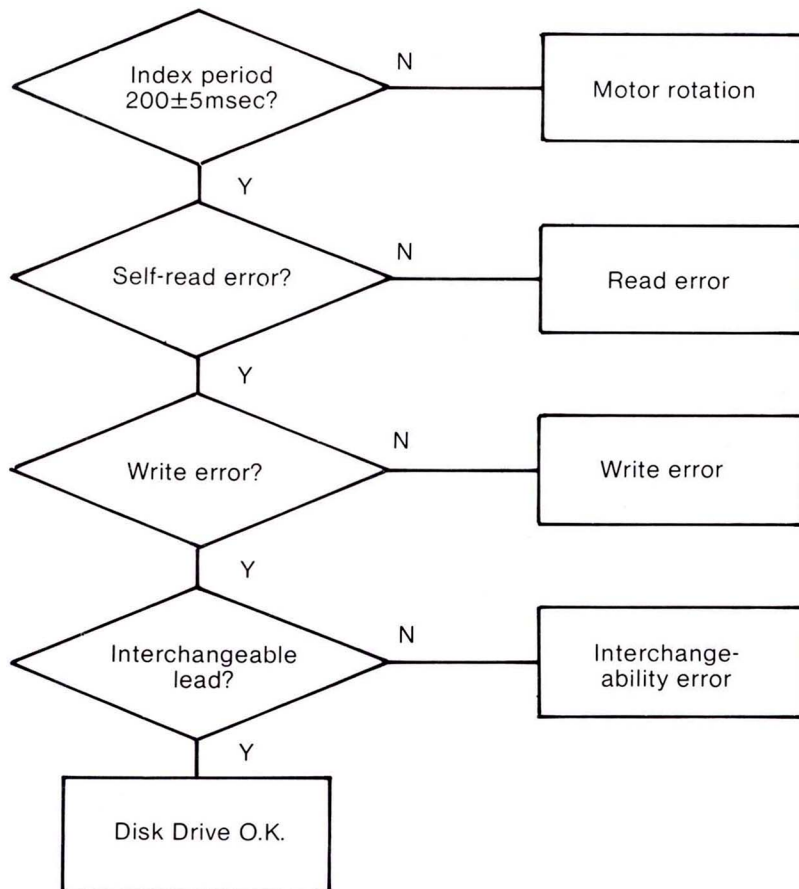

# FLOW CHART (cont)

3-B

Information within brackets is only for FD2

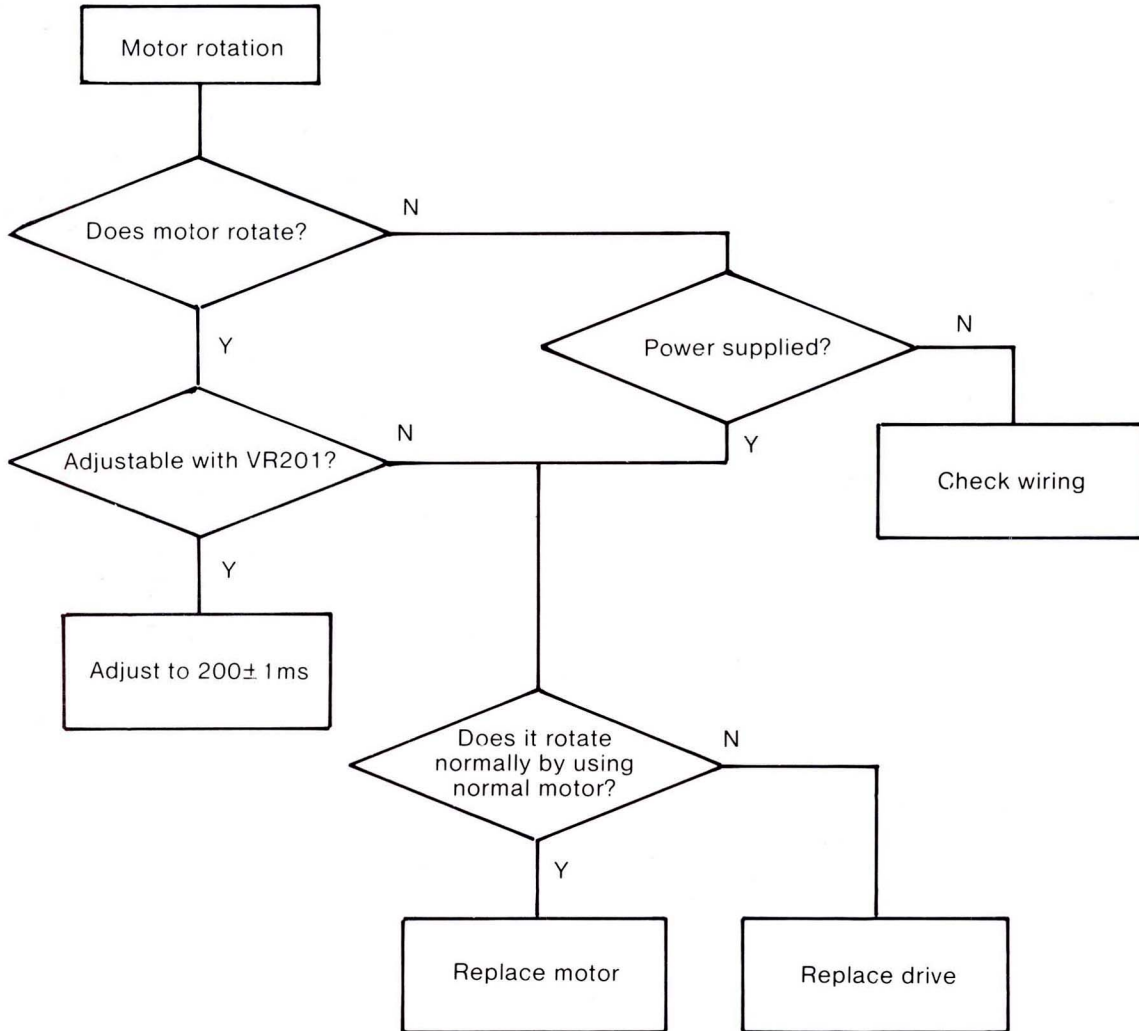

3-C

### FLOW CHART (cont)

Information within brackets is only for FD2

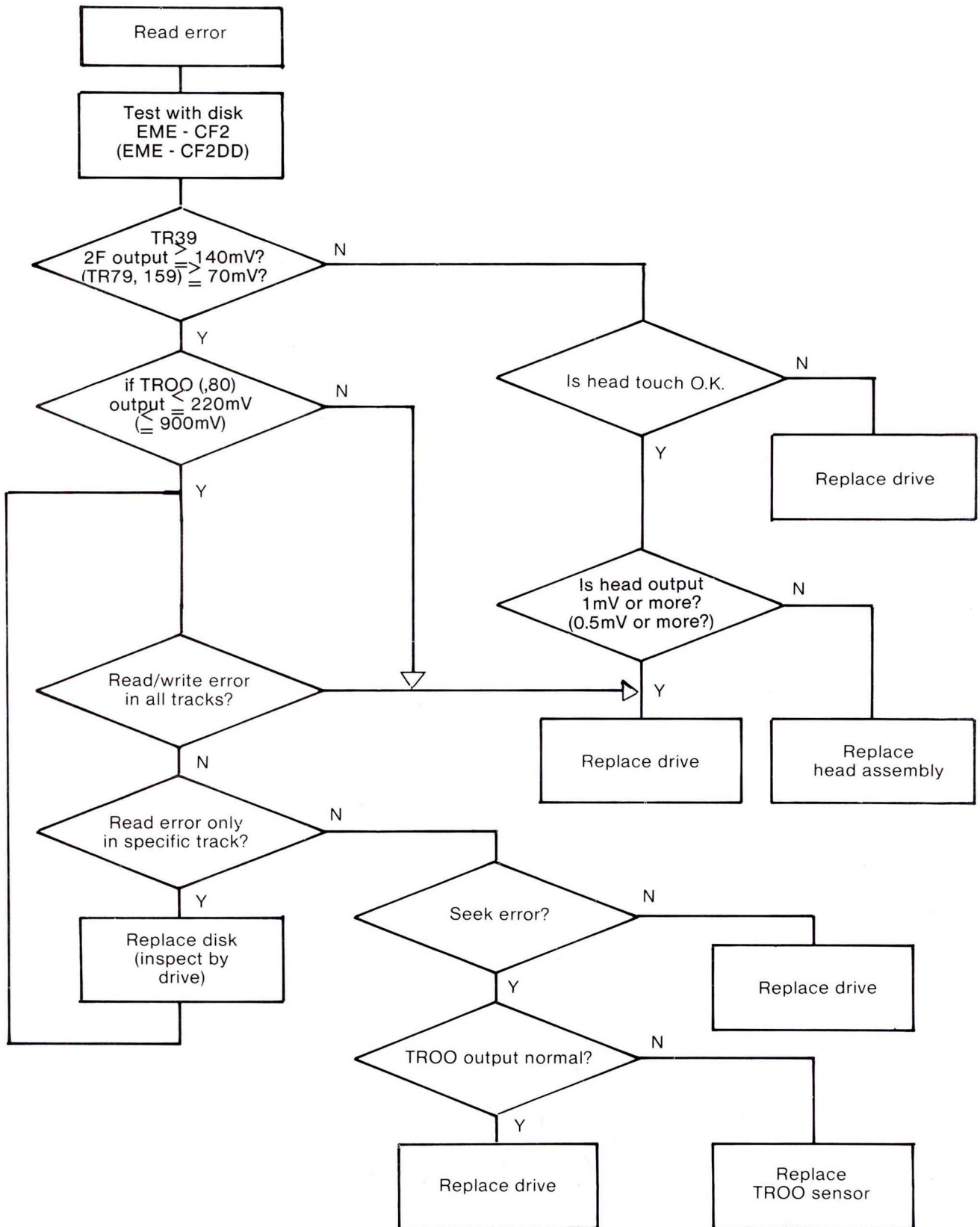

# FLOW CHART (CONT)

3-D

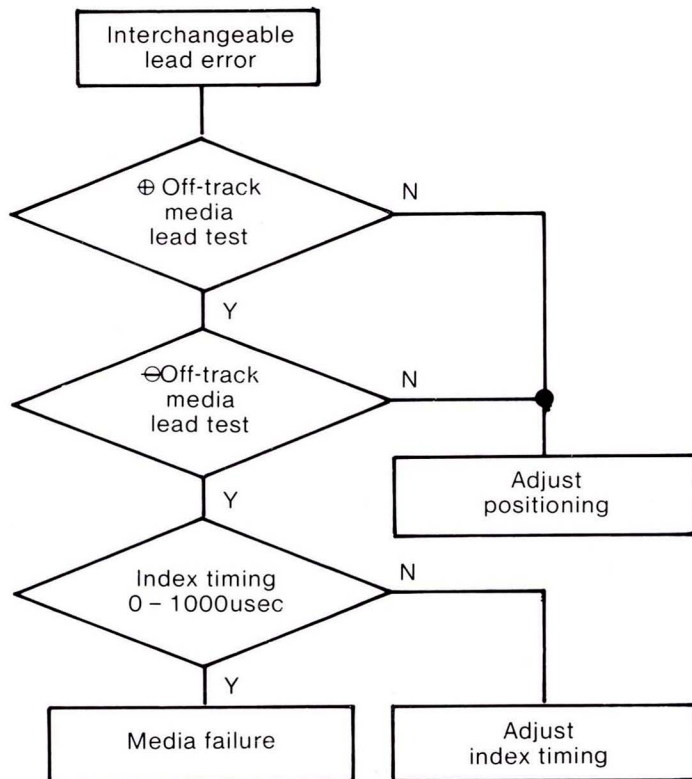
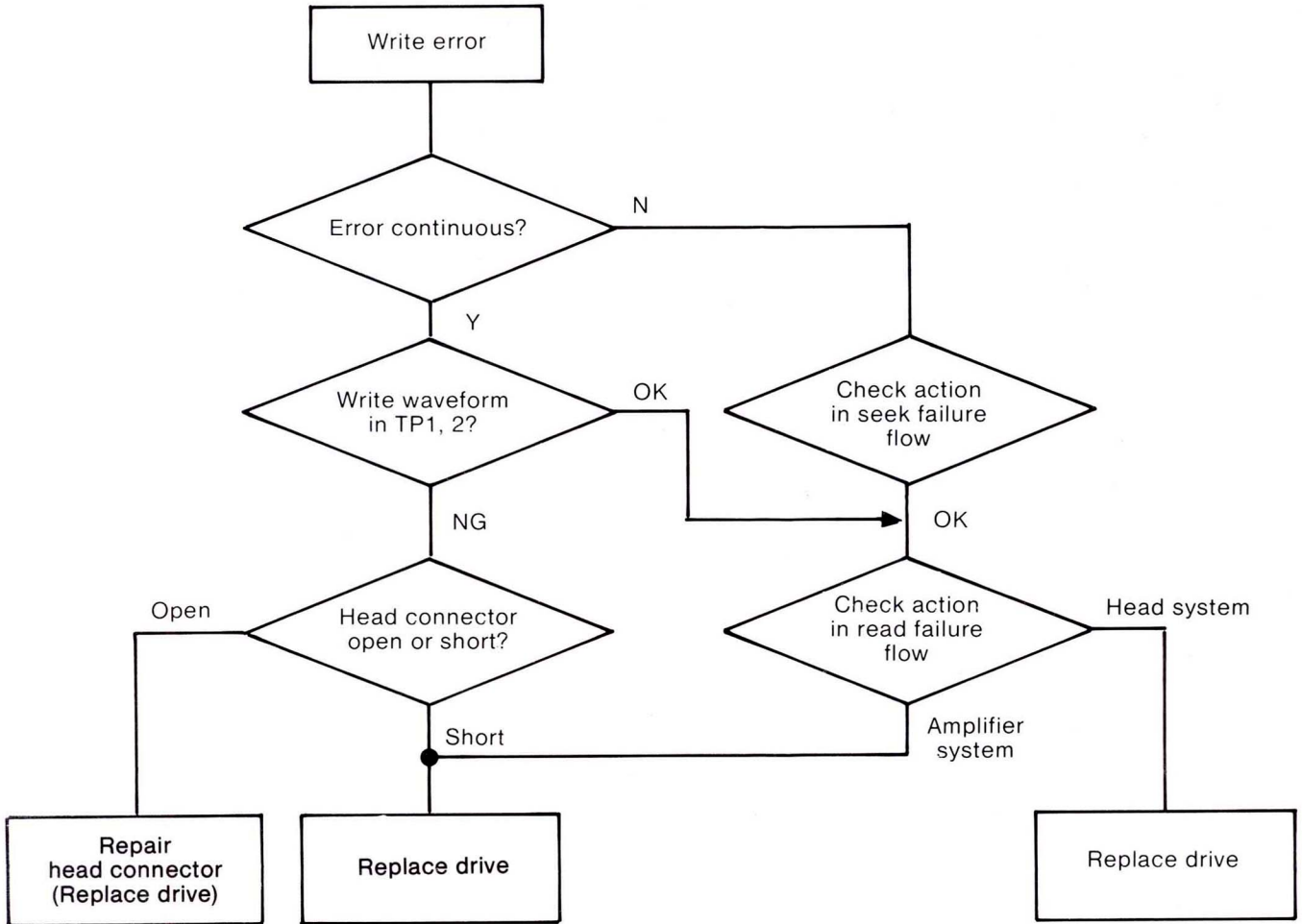



# FLOW CHART (CONT) FOR FD2 ONLY

3-E

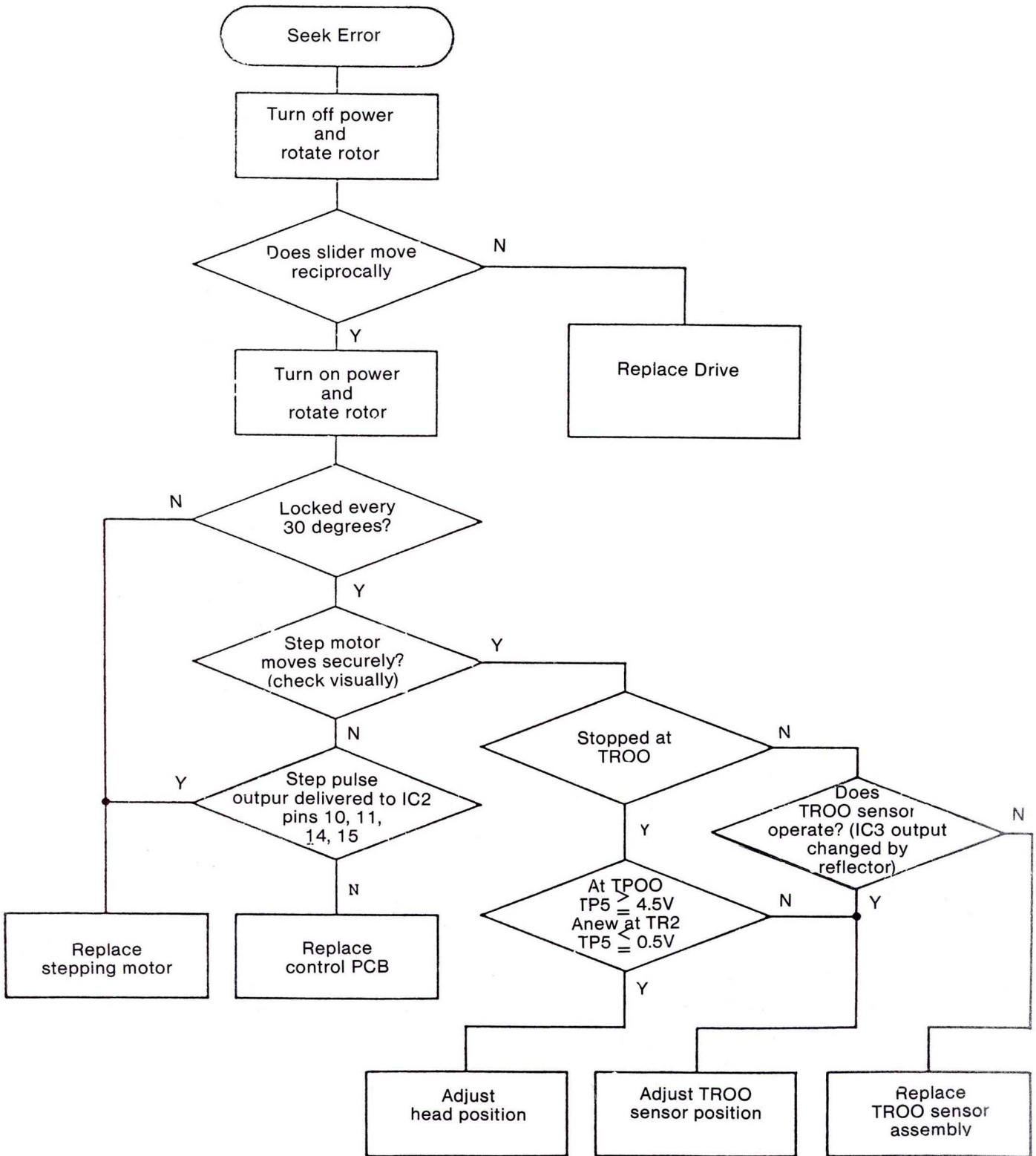

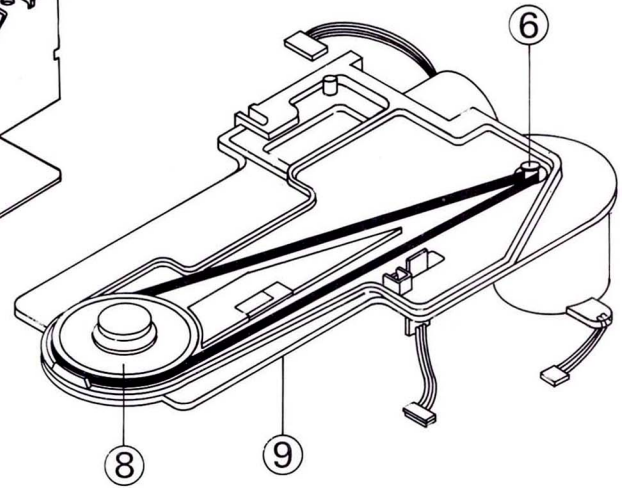
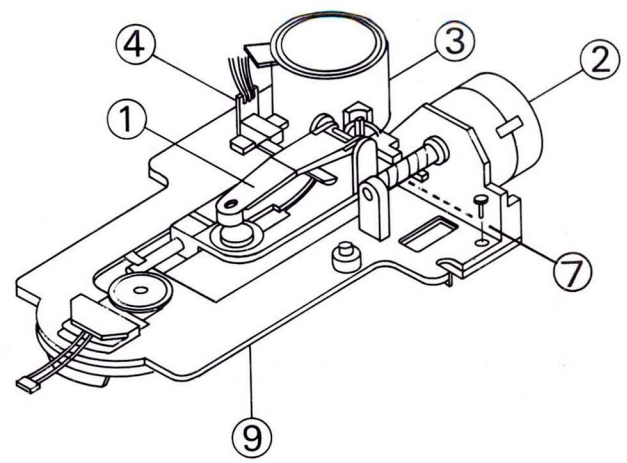
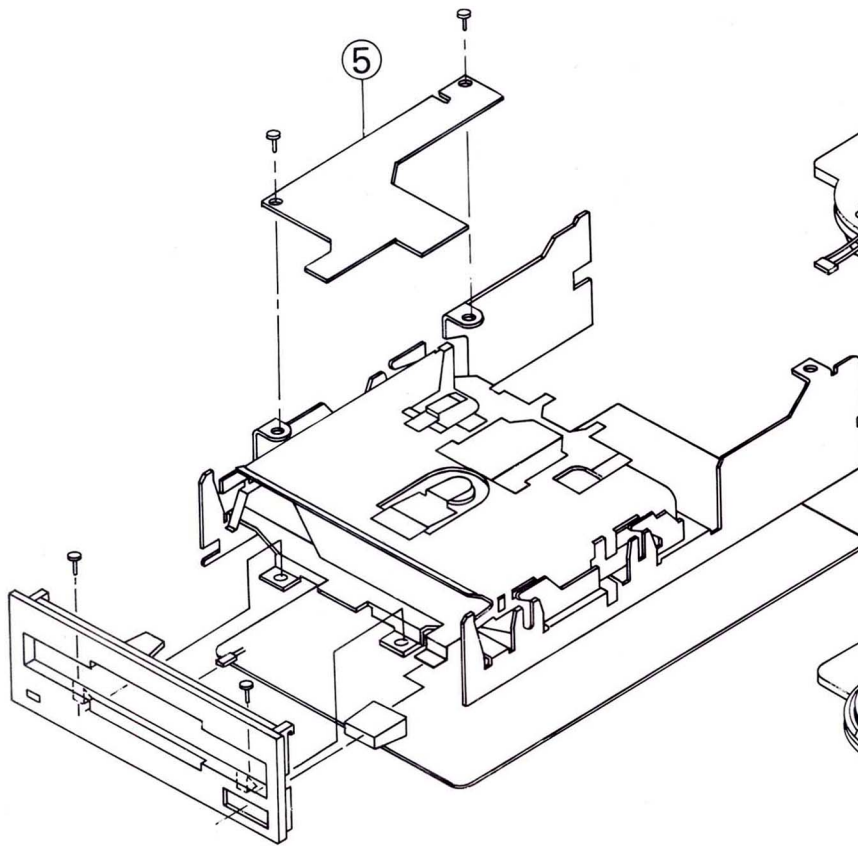

This drawing is for information only. During the warranty period Service Agents must return the Disc Drive Mechanism complete with PCB30001 for replacement.

## MECHANICAL REPLACEMENTS

### Head Assembly

- i) Remove 2 screws from F. panel and remove F. panel.
  - ii) Remove 4 screws from the control PCB.
  - iii) Disconnect plug from Stepper Motor.
  - iv) Disconnect plug from LED P.C.B.
  - v) Disconnect transistor from Spindle Motor.
  - vi) Disconnect Index Sensor from front of P.C.B.
  - vii) Raise P.C.B. from side opposite LED and remove plug from head.
  - viii) Control P.C.B. will now be free – remove.
  - ix) Remove 4 screws securing the Loading Unit to the chassis from the Flywheel side and remove Loading Unit.
  - x) Remove spring and rod support screws.
  - xi) Gently slide the head off the rod.
  - xii) Replacement is reverse process.
- After reassembly check alignment of Azimuth Burst/Track OO Positioning.

### Spindle Motor

- i) Remove transistor fitted to Motor.
- ii) Unplug CN5 from Control P.C.B.
- iii) Remove Drive Belt.
- iv) Undo 2 screws securing motor.
- v) Replacement is reversal of removal.
- vi) Adjust VR201 so index frequency is  $200 \pm 2\text{ms}$  (See Fig. 5-1).

### Stepper Motor

- i) Remove Control P.C.B. as (1).
- ii) Remove 2 securing screws for Stepper Motor Bracket.
- iii) Stepper Motor can now be removed.
- iv) After replacement index and positioning must be checked and amended as necessary.

Sym	Description
1.	Head Bracket Assembly
2.	Stepper Motor
3.	Spindle Motor
4.	Track OO Sensor
5.	Read/Write Protect Index/LED P.C.B.
6.	Pulley
7.	Stepper Motor Shaft
8.	Flywheel
9.	Loading Unit

The data contained in the following 4 pages is for information only. Service Agents must not carry out any repair or adjustment to the Drive mechanism and its associated PCB 30001 during warranty. Faulty mechanism must be returned to AMSTRAD for exchange.

## Alignment Checks

Information within brackets is only for FD2

Please use this information in conjunction with the diagnostic flow chart.

Equipment required: Double Beam Scope; EME - CF2 (EME - CF2DD) Test Disk (please refer to disk notes for usage).

The following checks can be carried out in routine servicing. If the wave patterns do not appear this confirms a fault with the mechanism. Before attempting any replacement check these waveforms thoroughly.

Content of adjustment and checking	CE DISK EME CF2
1. Radial adjustment by use of Track 19 (Fig. 1). (Track 39, 119).	○
2. Adjustment of the index burst by use of Track 39 (Fig. 2). (Track 79, 159).	○
3. Azimuth check by use of Track 39 (Fig 3-4). (Track 79, 159).	○

List of Test Points

Test point	Name of signal
TP 1	Read signal of filter outlet
TP 2	Read signal of filter outlet
TP 3	Signal ground
TP 5	TROO sensor output
TP 9	Index signal
TP 11	Signal ground

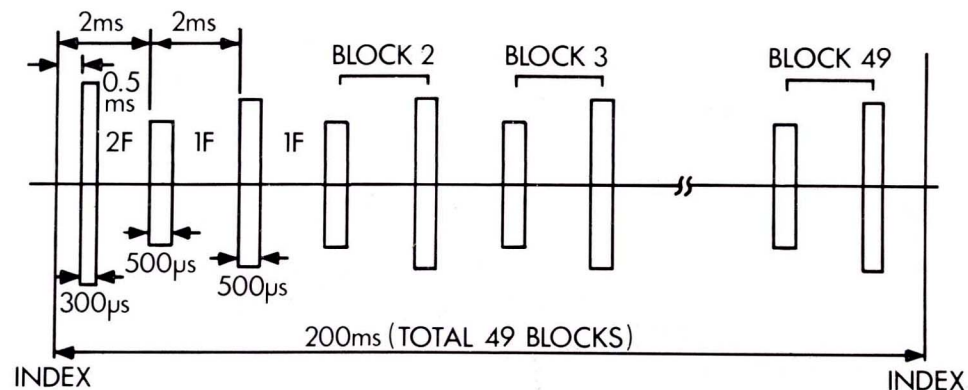

Fig.1 Waveform of T19 (Servo pattern)  
(T39, 119)

# ALIGNMENT CHECKS

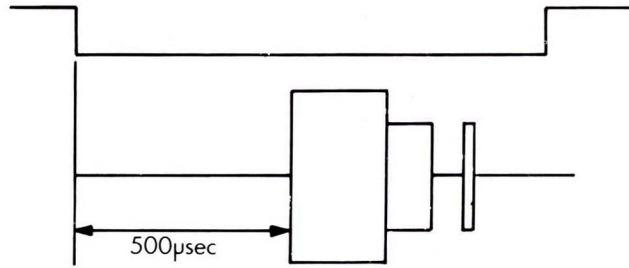

Fig. 5-1 Index burst waveform

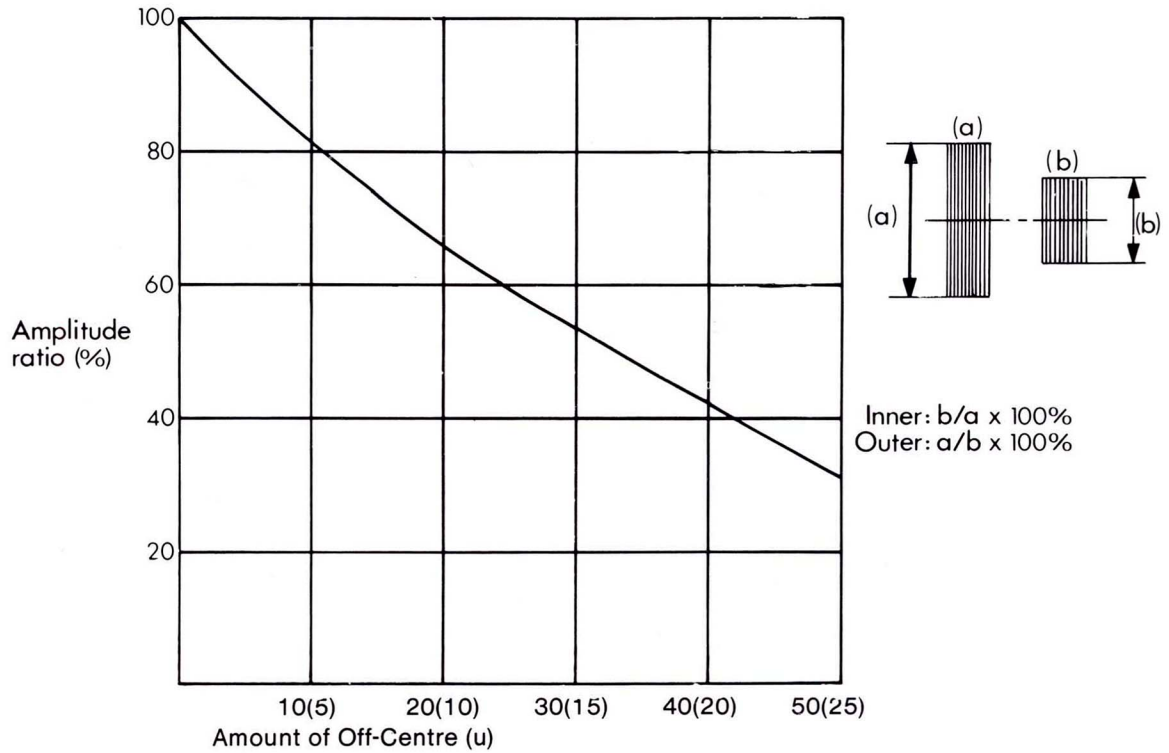

Fig. 5-2 Off-centre calibration curve  
[Effective width of read head is 180u] (90u).

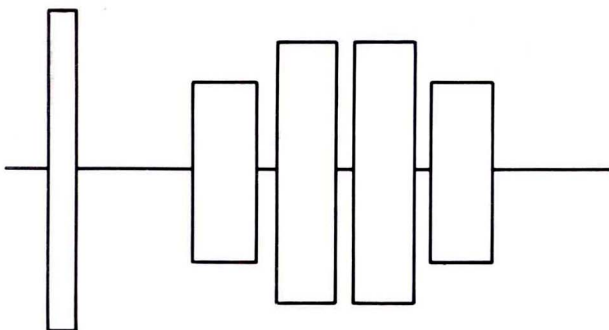

Fig. 5-3 Azimuth burst

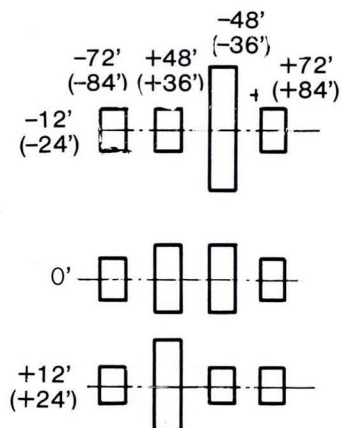

Fig. 5-4 shows azimuth burst in the cases of azimuth -12', 0' and +12'.  
(-24, 0 and +24).

# ALIGNMENT CHECKS (cont)

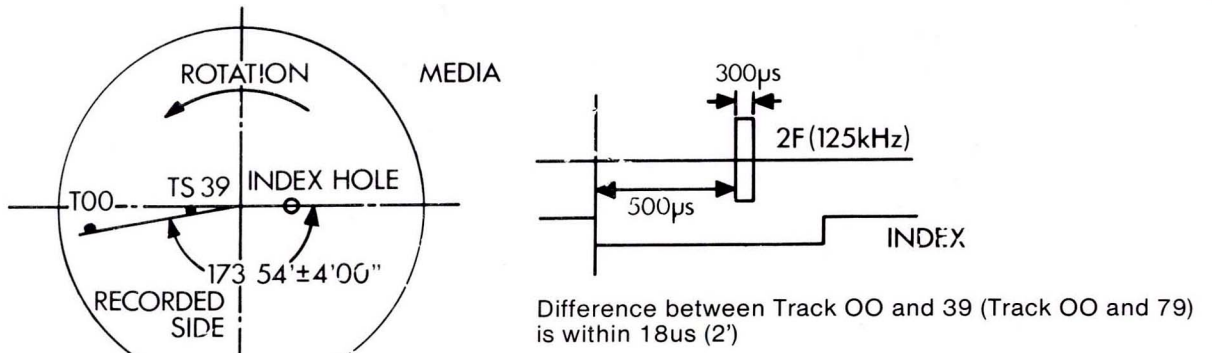

Fig. 2 Waveform of T39 (Index pattern – Radial alignment)  
(Waveform of T79, 159)

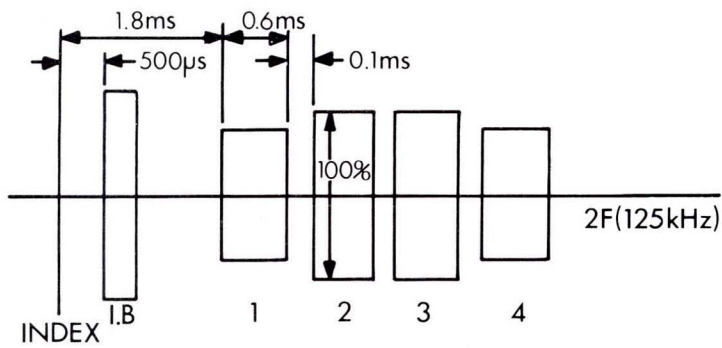

Fig. 3 Waveform of T39 (Azimuth, alignment)  
(Waveform of T79, 159)

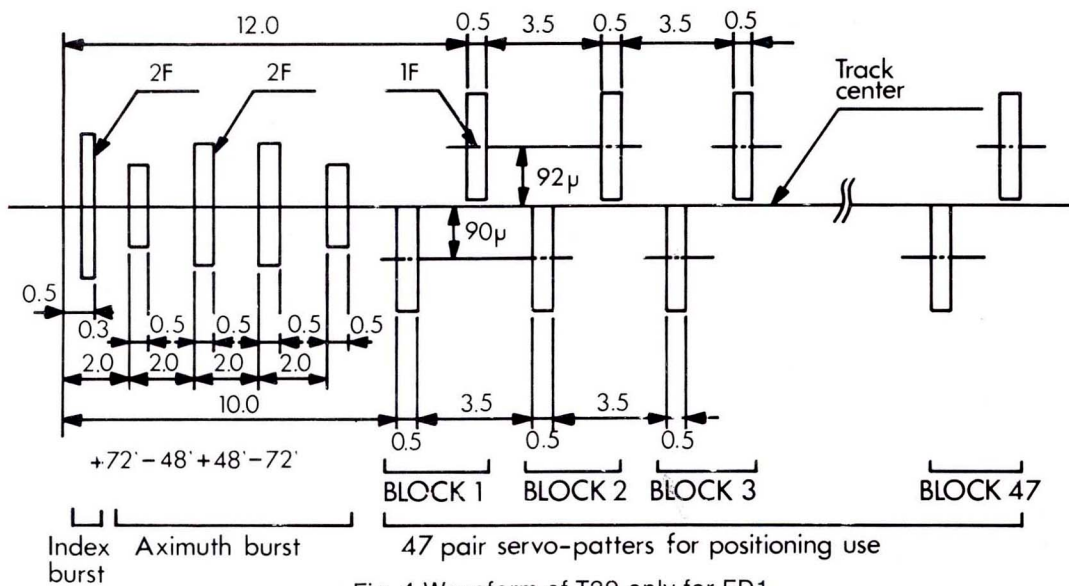

Fig. 4 Waveform of T39 only for FD1.

# ALIGNMENT CHECKS (cont)

## 1) Check Positioning

- 1) Load CE Disk.
- 2) Set up track OO, Motor off.
- 3) Scope to TP5.
- 4) Adjust OO Sensor (8 on Fig. 6) so that scope shows correct difference as Fig. 2.

## 2) Adjustment of Index Timing

- 1) Load the CE Disk (refer to disk info)
- 2) Step the disk to the track 39. (Track 79).
- 3) Synchronise the oscilloscope by TP9 (INDEX). Set the time base to 0.1 msec/DIV.
- 4) Connect the probe to TP1.  
Connect the ground probe to TP3 and TP11 (ground) of PCB.  
Set the input to AC and set the vertical axis to 20mV/DIV.
- 5) Measure timing between sweep start and an initial data pulse. It should be 500 usec  $\pm$ 500 usec. When the timing is not within this range, proceed with the following adjustment. (Refer to Fig. 5-1).
- 6) Loosen the two screws fixed LED printed board. Adjust the position of LED printed board so that the timing is 500 usec  $\pm$ 100 usec. ( $\pm$ 200 usec).
- 7) Re-check the timing.
- 8) Seek to the track OO and make sure that the timing is within 500 usec  $\pm$ 200 usec ( $\pm$ 300 usec). Tighten the screws. (Fig. 5-1).

## 3) Check of Head Output

This check is effective only when making write and read check as described below. If the output level is less than the prescribed output, clean the head before check.

Disk used for this check must be in good condition.

- 1) Load the CE Disk. \* (Appropriate for FD1 or FD2).
- 2) Select track 39. (Track 79).
- 3) Connect one of the probes of the oscilloscope to TP1 of the printed circuit board, another probe to TP2, and the probe to ground to TP3, TP11 (ground).  
Invert one channel, and set it to Add input, set input to AC, and set the vertical axis to 50mV/DIV and the horizontal axis to 20msec/DIV.
- 4) Make sure the average output level is the following value or more: 140 mV p-p (70 mV p-p) [SN 25dB or more]. If the output is less than the above-described value, replace the head.

## 4) Adjustment of Positioning

- 1) Load the CE disk \*.
- 2) Select track 19. (Track 39).
- 3) Monitor the output in the same way as the head output inspection.  
Calculate the off-track amount in reference to the calibration graph, showing the interrelation between the burst amplitude ratio and off-track amount. (Refer to Fig. 5-2).
- 4) The average of amplitude ratio should be below 26  $\mu$ m. (19  $\mu$ m).  
If it is not within this range, make the following adjustment.
  - i) Loosen the bolt of the rotation stopper which fixes the screw shaft (Fig. 6-3).  
Rotate the screw shaft and adjust it in such a way that the amplitude ratio may become below 15  $\mu$ M (5  $\mu$ M). Tentatively set the bolt at that position.
  - ii) Make the track step to the inner and outer circles and bring it to the original position. Make sure that the adjustment is all right. Then, tighten the bolt.

## 5) Confirmation of Head Azimuth

- 1) Load the CE Disk \*.
- 2) Select track 39. (Track 79).
- 3) Synchronise the probe of the oscilloscope by TP9 of PCB and connect another probe to TP1, and the probe ground to TP3, TP11 (ground). Set the input to AC, the vertical axis to 10mV/DIV, and the horizontal axis to 0.5msec/DIV. Make sure that the two outside burst waveforms are smaller than two inside burst waveforms as shown in Fig. 5-3.  
Note: Signal preceding the azimuth burst is the index burst.  
If the azimuth is still incorrect replace the head assembly.

# FD1 Schematic Diagram

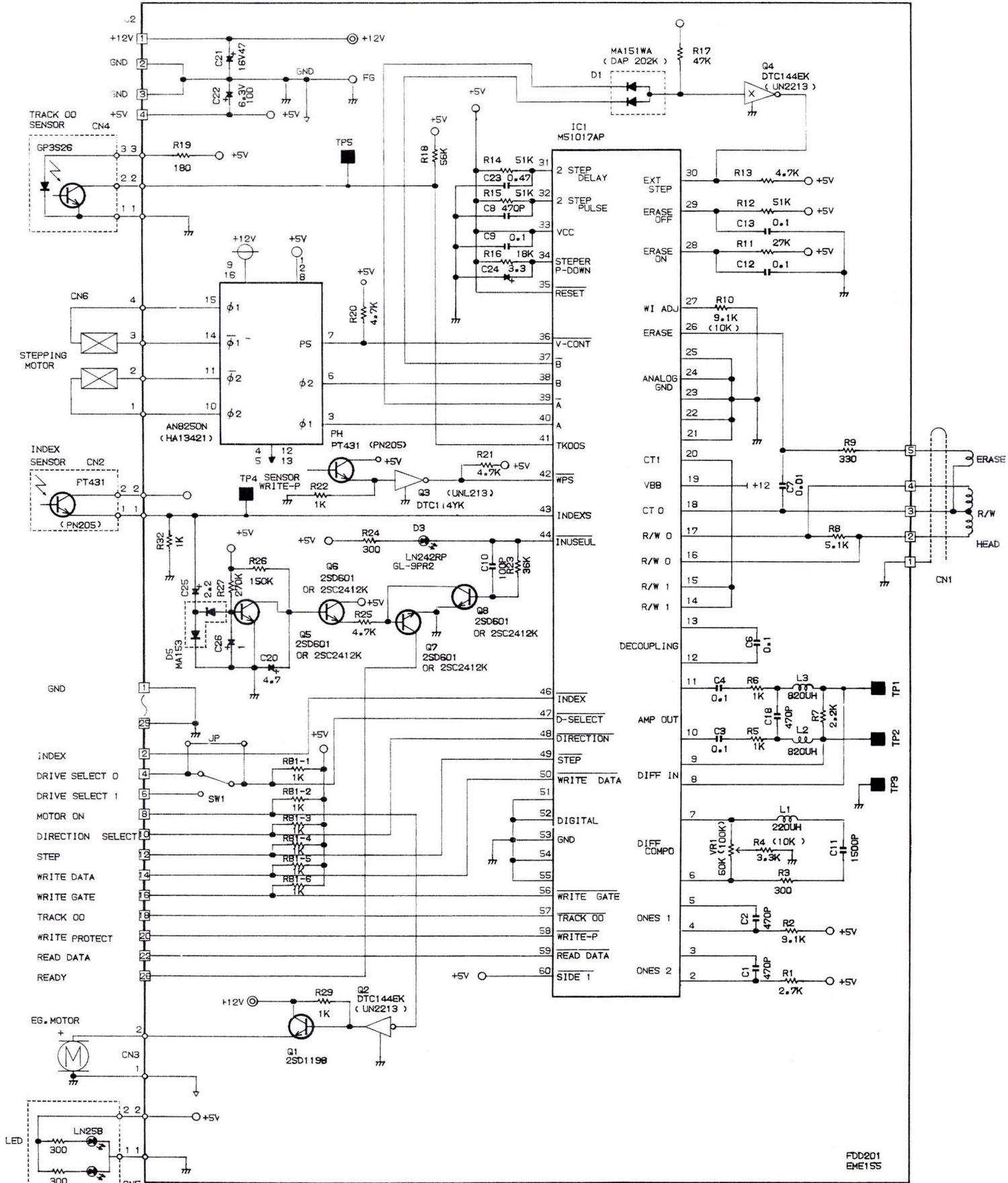

FDD201  
EME155

ATTENTION : LES PIÈCES RÉPARÉES PAR UN ÉTANT DANGEREUSES AN POINT DE VUE SECURITE N'UTILISER QUE CELLES DECRITES DANS LA NOMENCLATURE DES PIÈCES.

NOTE: THIS SCHEMATIC DIAGRAM IS THE LATEST AT THE TIME OF PRINTING AND SUBJECT TO CHANGE WITHOUT NOTICE.

## SCHEMATIC DIAGRAM

M211-04 1-4198

# FD2 SCHEMATIC DIAGRAM

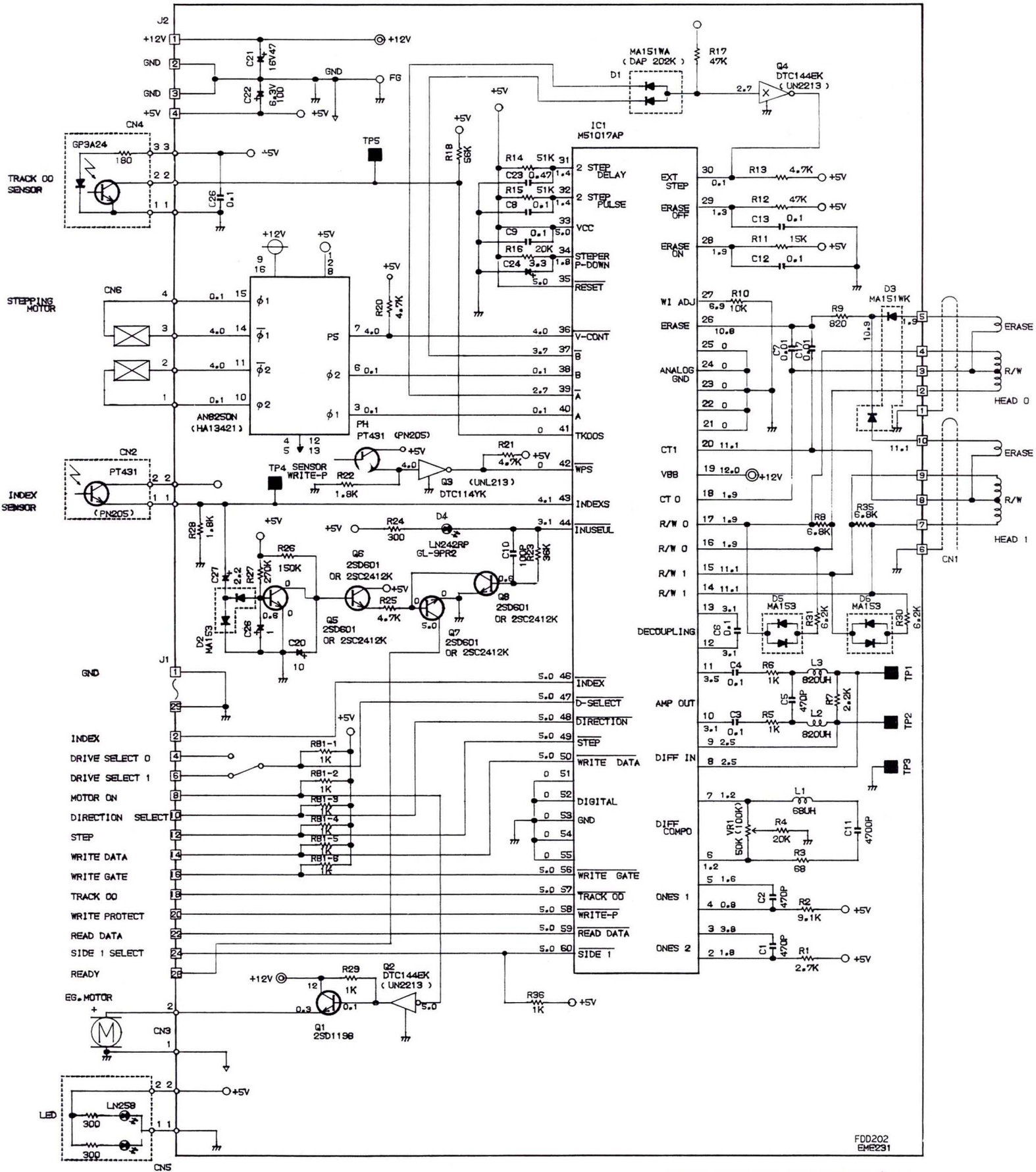

FDD202  
EME291

CAUTION: SINCE THESE PARTS MARKED BY ARE CRITICAL FOR SAFETY, USE ONES DESCRIBED ON PARTS LIST ONLY.



## ALIGNMENT CHART FOR THE MONITOR

Equipment required: Digital Voltmeter; Oscilloscope; Frequency Counter; Test Pattern Generator; RP3 or Pattern Disc.

### ALIGNMENT INSTRUCTIONS

STEP	FUNCTION	SIGNAL IN	SIGNAL OUT	METHOD	REMARKS
1.	D.C. 12V Adjustment	Pin 3/CD101	Pin 2/CD102	Adjust VR2001 to Max. Adjust VR5002 to read 12V @ 2%.	Disconnect CD101 to perform the test.
2.	D.C. 5V Adjustment.	Pin 3/CD101	Pin 3/CD102	Adjust VR2001 to Max. Adjust VR5001 to read 5V @ 2%.	Disconnect CD101 to perform the test.
3.	V. Size Adjustment.	Pin 3/CD101.	Monitor Screen.	Adjust VR4002 for full size @ 0%.	Adjust Brightness control as required.
4.	V. Linearity Adjustment.	Pin 3/CD101.	Monitor Screen.	Adjust VR4003 to get Up/Down space from the centre of the circle in the test pattern.	
5.	H. Hold Adjustment.	Free run no input.	Pin 1/CP4001	Adjust VR4005 to read frequency 15625kHz.	
6.	V. Size. V. Linearity.	Use RP3 or Pattern Disc.	Monitor Screen.	Adjust VR4002 to get top & bottom border to measure 15mm. Adjust VR4003 to get left & right borders to measure 16mm.	Connect CD101 to the CPU P.C.B.
7.	Cut Off Adjustment.		Monitor Screen.	Brightness Control to Min. ie VR2001. Adjust VR4004 to get faint screen. Increase Brightness to measure 100% white on lux meter. Adjust VR 2001 at the centre of the screen.	

### WAVEFORM DIAGRAMS

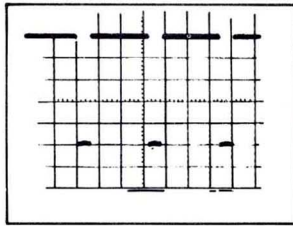

① 5V P-P

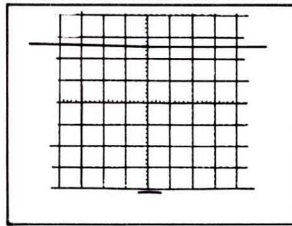

② 0.2V P-P

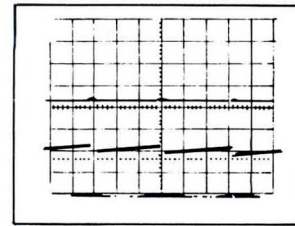

③ 0.8V P-P (H)

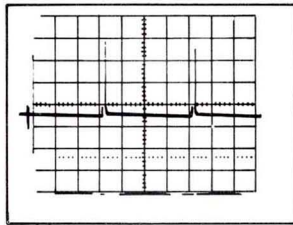

④ 3.8V P-P (V)

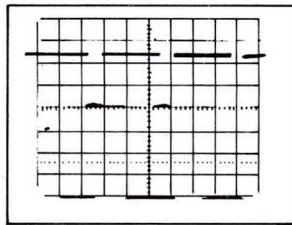

⑤ 2.5V P-P

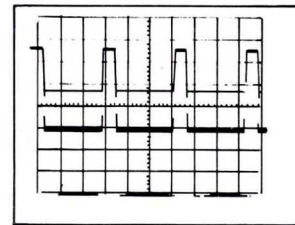

⑥ 38V P-P

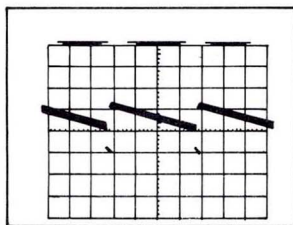

⑦ 10.2V P-P (V)

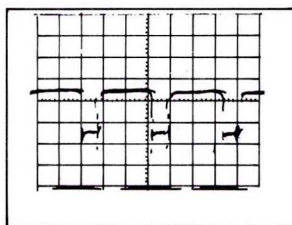

⑧ 7.6V P-P (H)

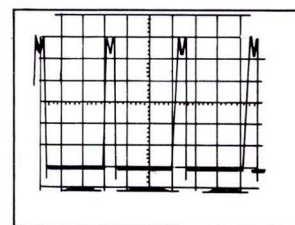

⑨ 72V P-P (H)

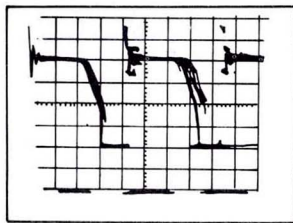

⑩ 560V P-P

Figures 1 to 10 correspond with test points marked on the circuit diagram.

# MONITOR SCHEMATIC DIAGRAM

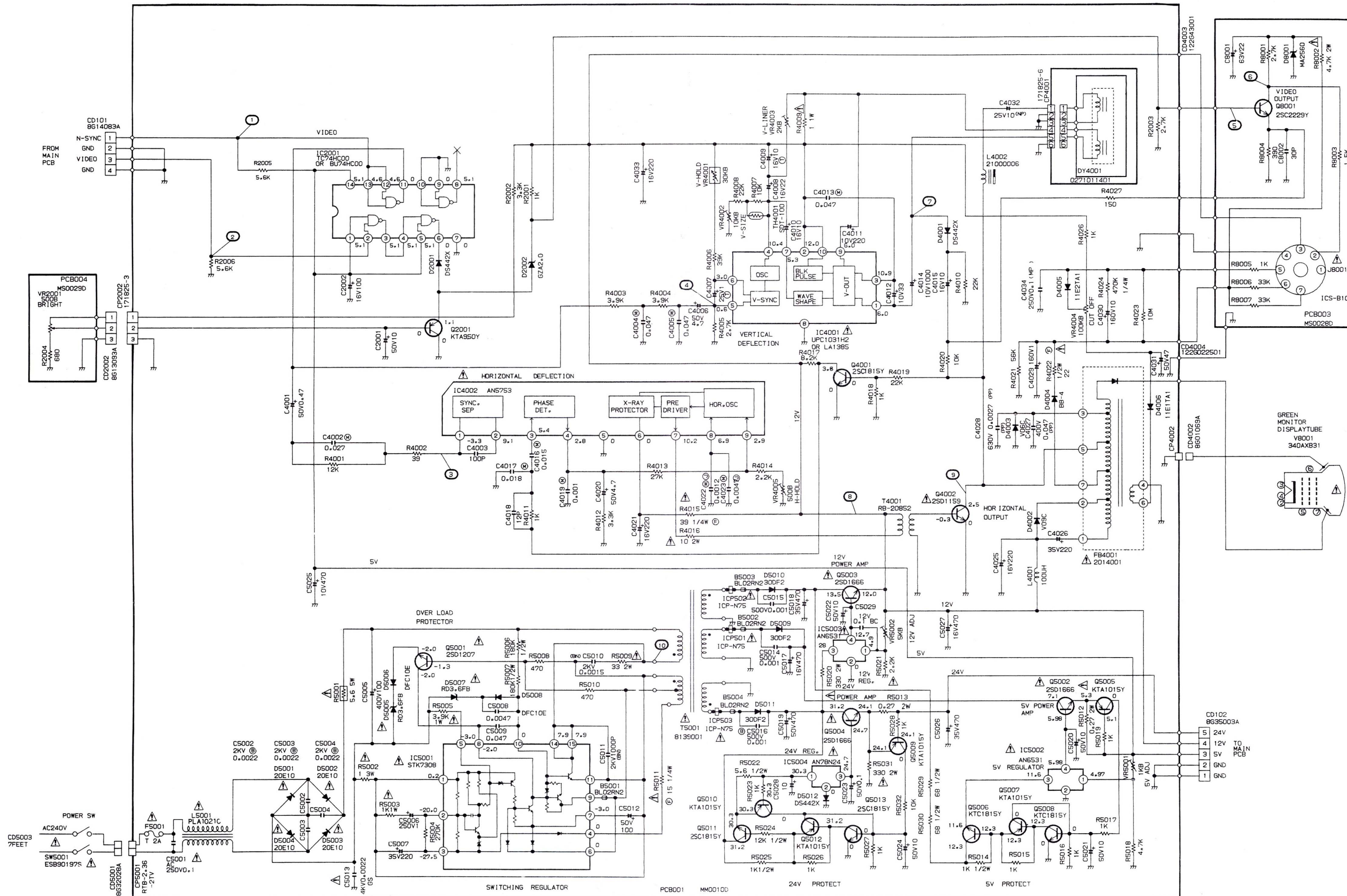

CAUTION: SINCE THESE PARTS MARKED BY  $\Delta$  ARE CRITICAL FOR SAFETY USE ONES DESCRIBED ON PARTS LIST ONLY.

ATTENTION: LES PIECES REPARÉES PAR UN  $\Delta$  ETANT DANGEREUSES AN POINT DE VUE SECURITE N'UTILISER QUE CELLES DECRITES DANS LA NOMENCLATURE DES PIECES.

NOTE: THIS SCHEMATIC DIAGRAM IS THE LATEST AT THE TIME OF PRINTING AND SUBJECT TO CHANGE WITHOUT NOTICE.

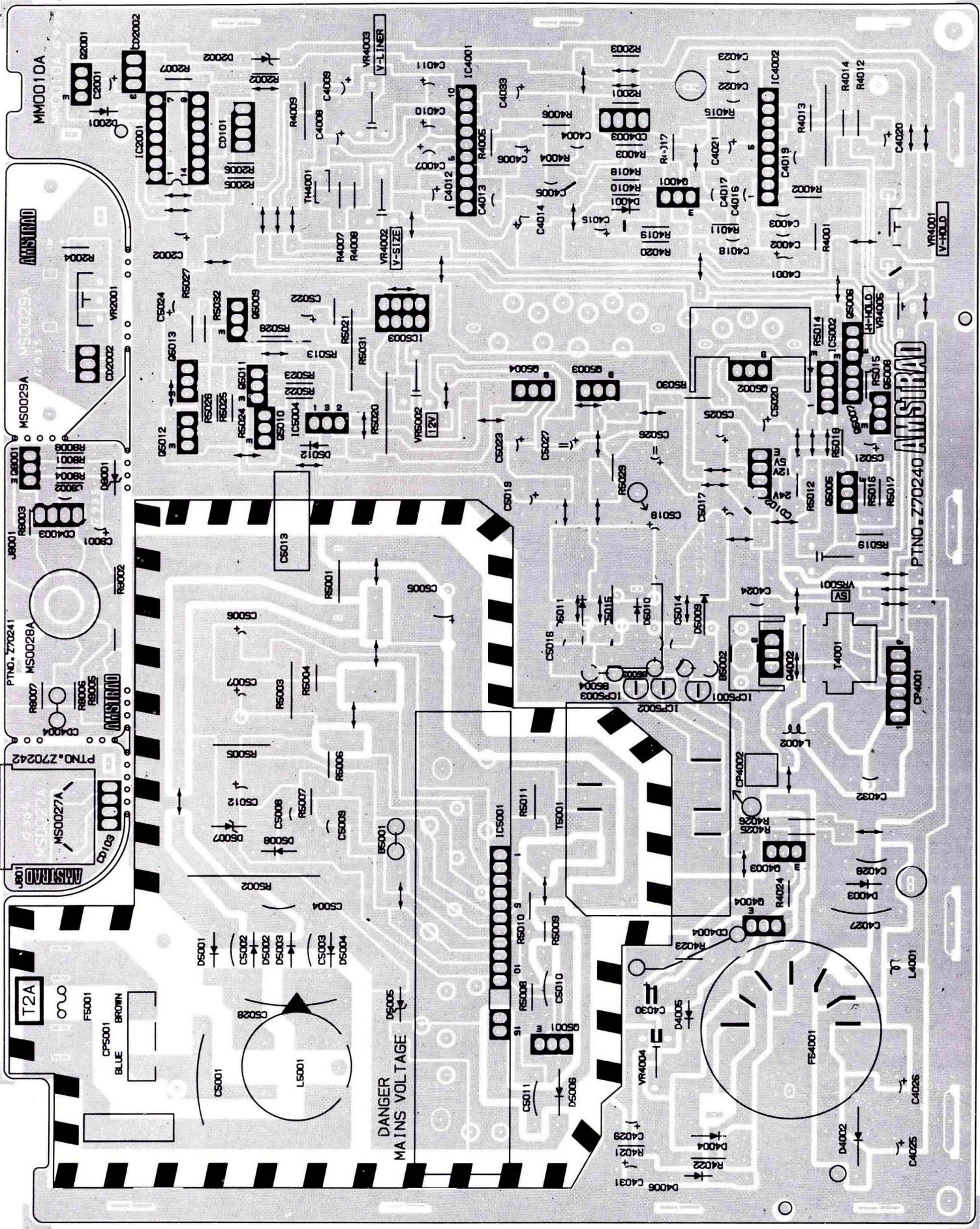

MONITOR P.C.B.

# MONITOR PCB — COMPONENT LAYOUT

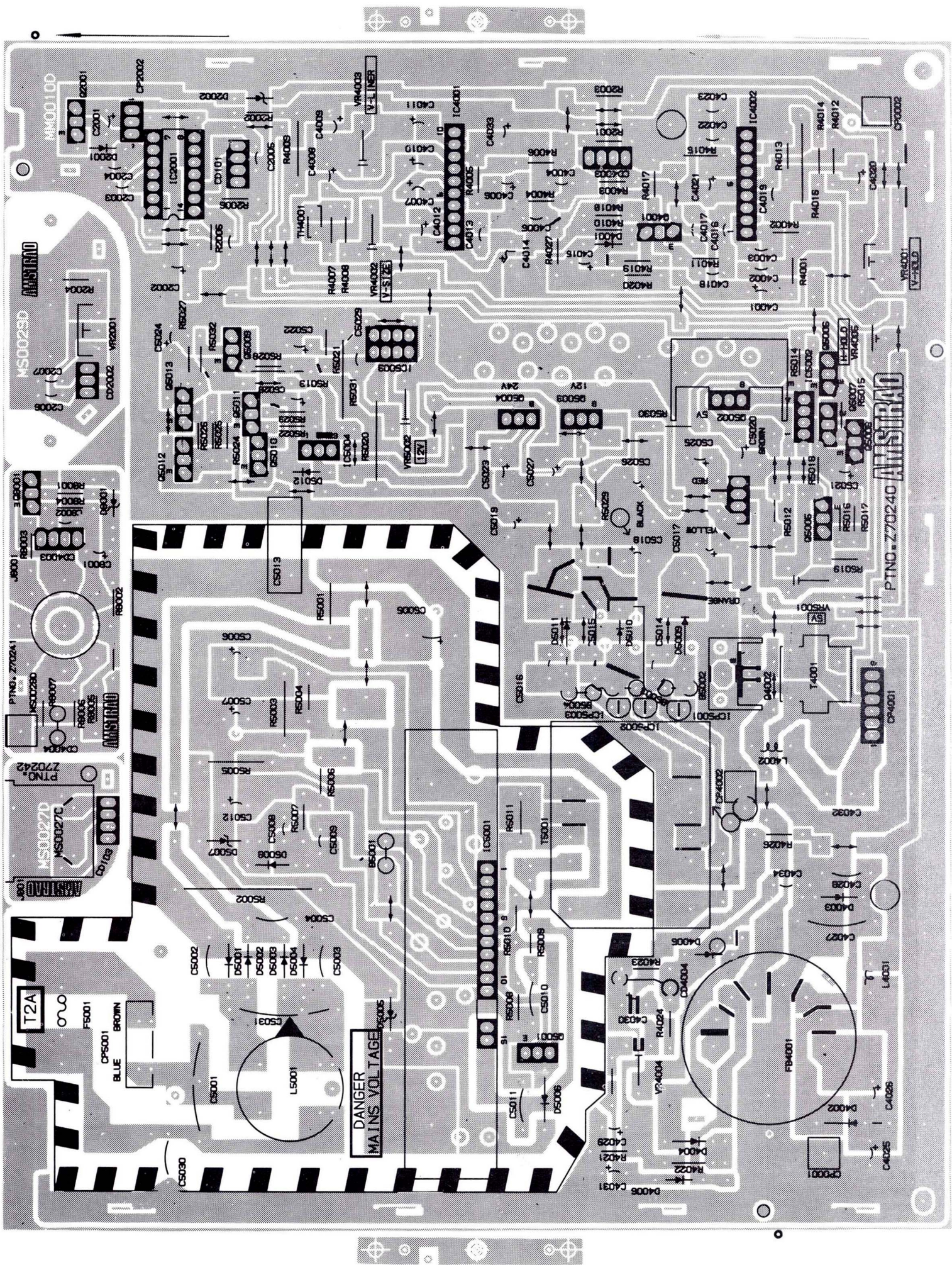

MECHANICAL EXPLODED VIEW

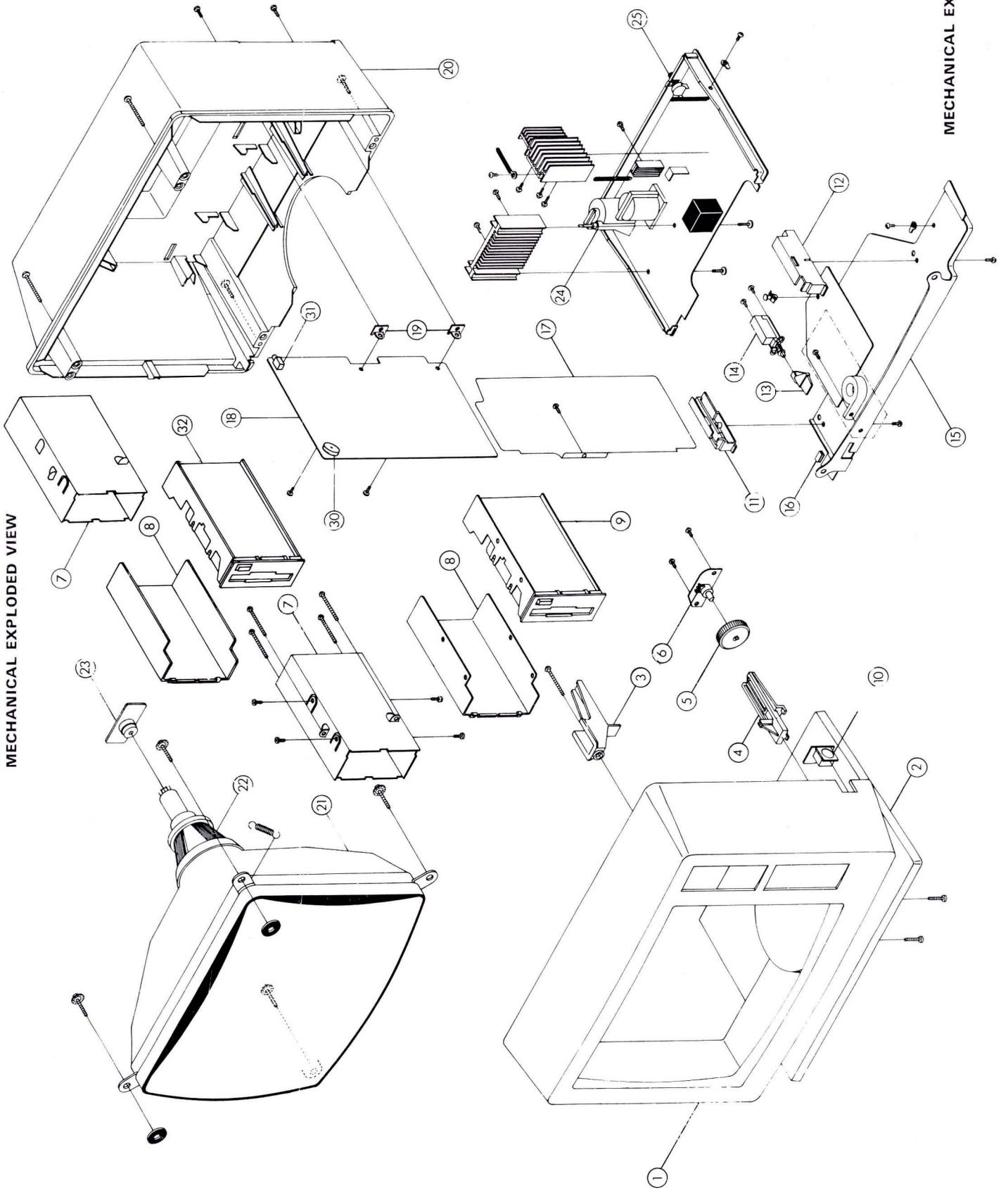

MECHANICAL EXPLODED VIEW

**CABINET EXPLODED VIEW**

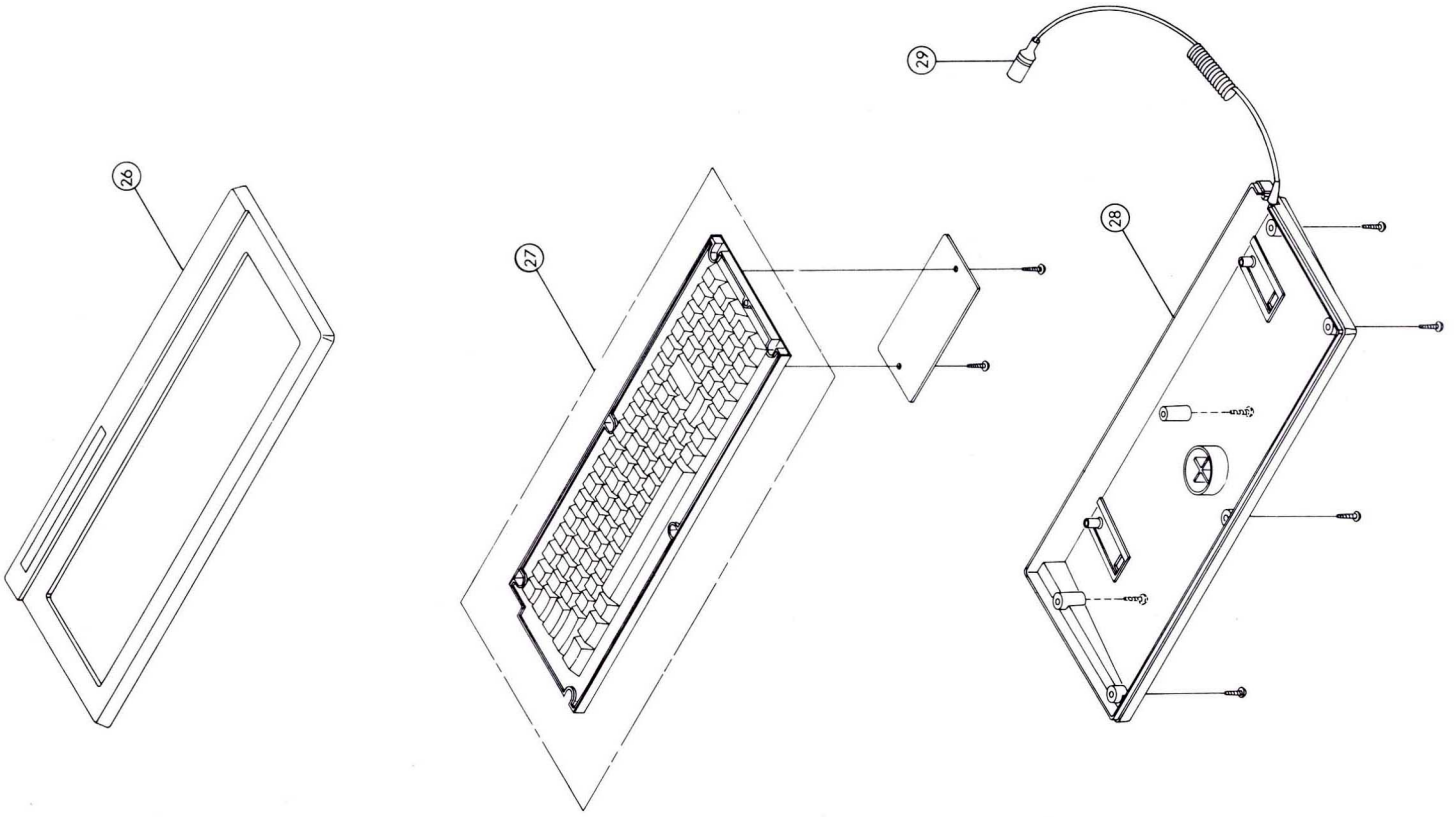

**CABINET PARTS LIST**

Ref.	Description	8256 Part No.	8512 Part No.
1	Fronat Cabinet Assembly	171001	171215
2	Cabinet Stand	171002	171216
3	Holder P.C.B. Top	171003	171003
4	Holder P.C.B. Bottom	171004	171004
5	Knob Control	171005	171217
6	Brightness Control	171006	171006
7	Frame FDD	171007	171007
8	Plate FDD Shield	171008	171008
9	Compact Floppy Disc Drive EME-155	190005	
10	4 Pin DIN Socket TCS4440-01-1011	171009	171009
11	Holder P.C.B. (L)	171010	171010
12	Holder P.C.B. (R)	171011	
13	Button Power	171012	171218
14	Switch Push - Power On/Off	171013	171013
15	Frame Bottom with Shield Plate	171014	171014
16	Edging	171015	171015
17	Sheet-Cover	171016	171016
18	CPU P.C.B. Assembly MC0015Q	171017	
19	Angle P.C.B.	171018	171018
20	Cabinet Back Assembly	171019	171219
21	CRT 340AXB31	171020	171020
22	Deflection Yoke DY0271011401	171021	171021
23	CRT Socket ICS-B103	171022	171022
24	Tx. Flyback 2014001	171023	171023
25	V. Hold Pot.	171024	171024
26	Cabinet Top Assembly Key Board	171025	171222
27	Switch Key Board	171026	171026
28	Cabinet Bottom Assembly	171027	171223
29	Cord DIN 8SE52001	171028	171233
30	Buzzer Pie 20 Electric EFB-RD24COIB	171061	171230
31	D.C. Jack HEC0470-01-630	170024	170024
32	Compact Floppy Disc Drive EME-231		171224

# KEYBOARD CIRCUIT DIAGRAM

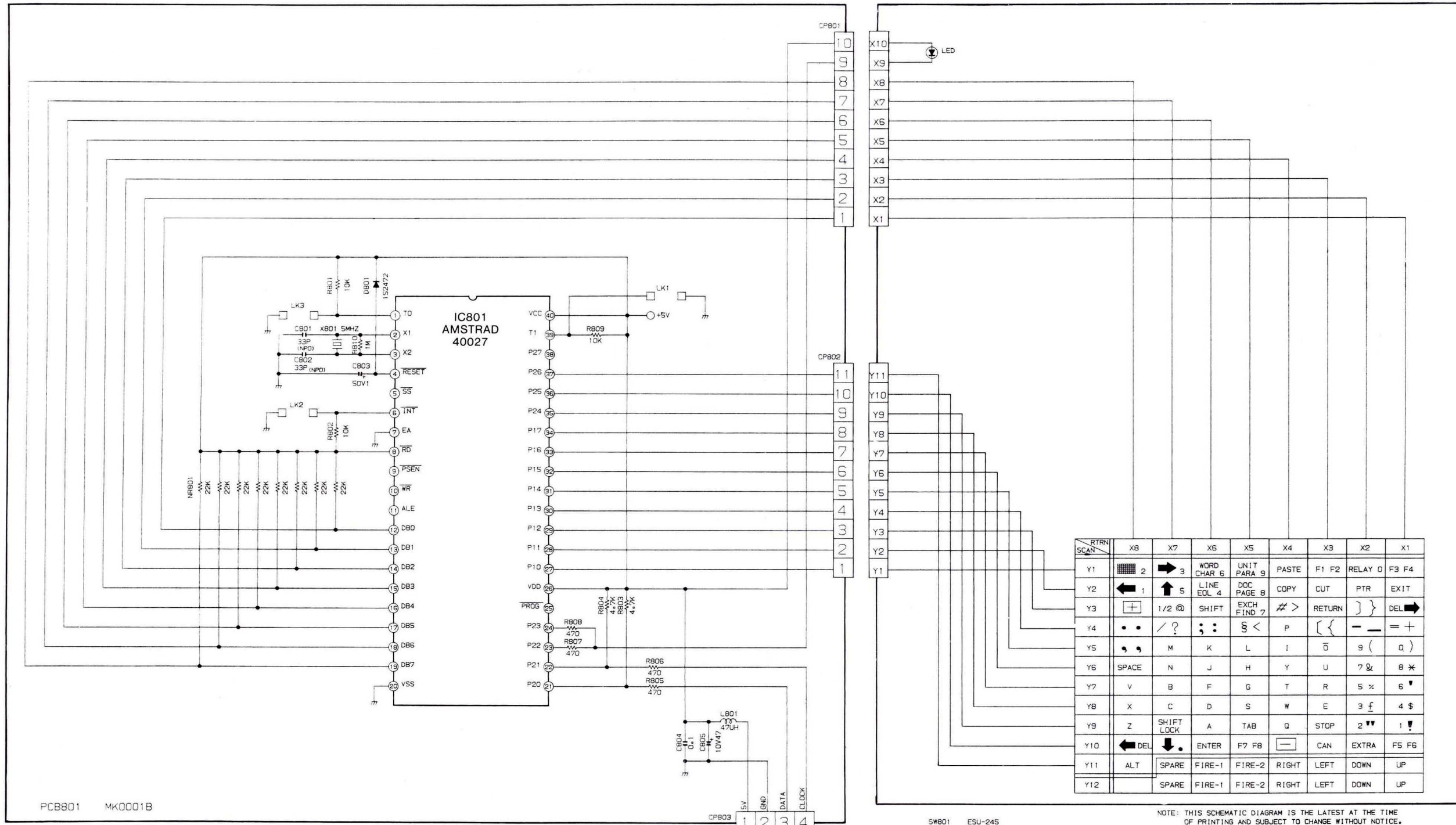

PCB801 MK0001B

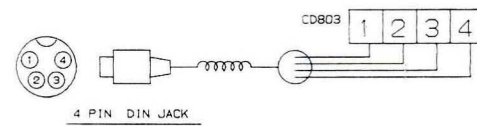

# Keyboard Control P.C.B.

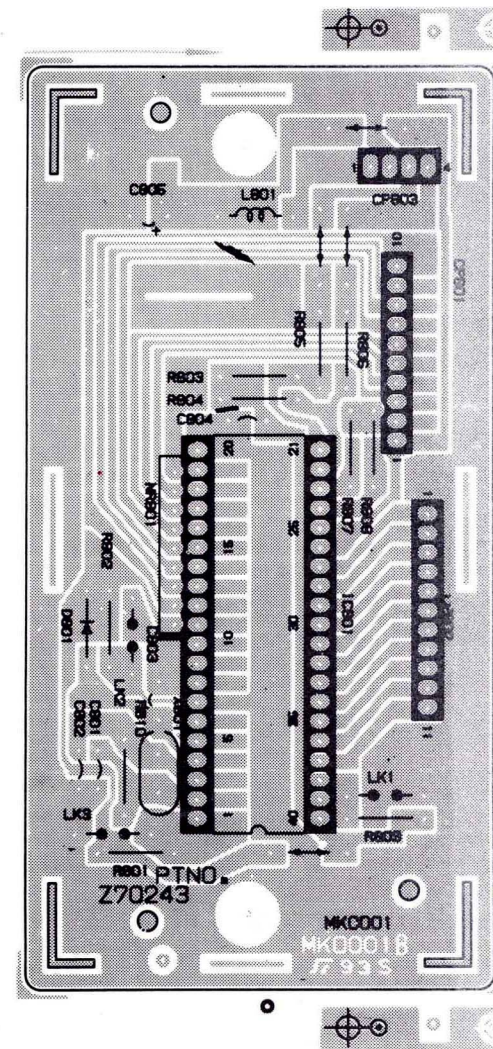

RTRN/SCAN	X8	X7	X6	X5	X4	X3	X2	X1
Y1	2	3	WORD CHAR 6	UNIT PARA 9	PASTE	F1 F2	RELAY 0	F3 F4
Y2	1	5	LINE EOL 4	DOC PAGE 8	COPY	CUT	PTR	EXIT
Y3	+	1/2 @	SHIFT	EXCH FIND 7	>	RETURN	}	DEL →
Y4	.	/ ?	:	S <	P	{	-	= +
Y5	,	M	K	L	I	0	9 (	Q )
Y6	SPACE	N	J	H	Y	U	7 &	8 *
Y7	V	B	F	G	T	R	5 %	6 ^
Y8	X	C	D	S	W	E	3 f	4 \$
Y9	Z	SHIFT LOCK	A	TAB	Q	STOP	2 "	1 !
Y10	← DEL	↓	ENTER	F7 F8	—	CAN	EXTRA	F5 F6
Y11	ALT	SPARE	FIRE-1	FIRE-2	RIGHT	LEFT	DOWN	UP
Y12		SPARE	FIRE-1	FIRE-2	RIGHT	LEFT	DOWN	UP

NOTE: THIS SCHEMATIC DIAGRAM IS THE LATEST AT THE TIME OF PRINTING AND SUBJECT TO CHANGE WITHOUT NOTICE.

# CHASSIS SCHEMATIC DIAGRAM

CPU P.C.B.

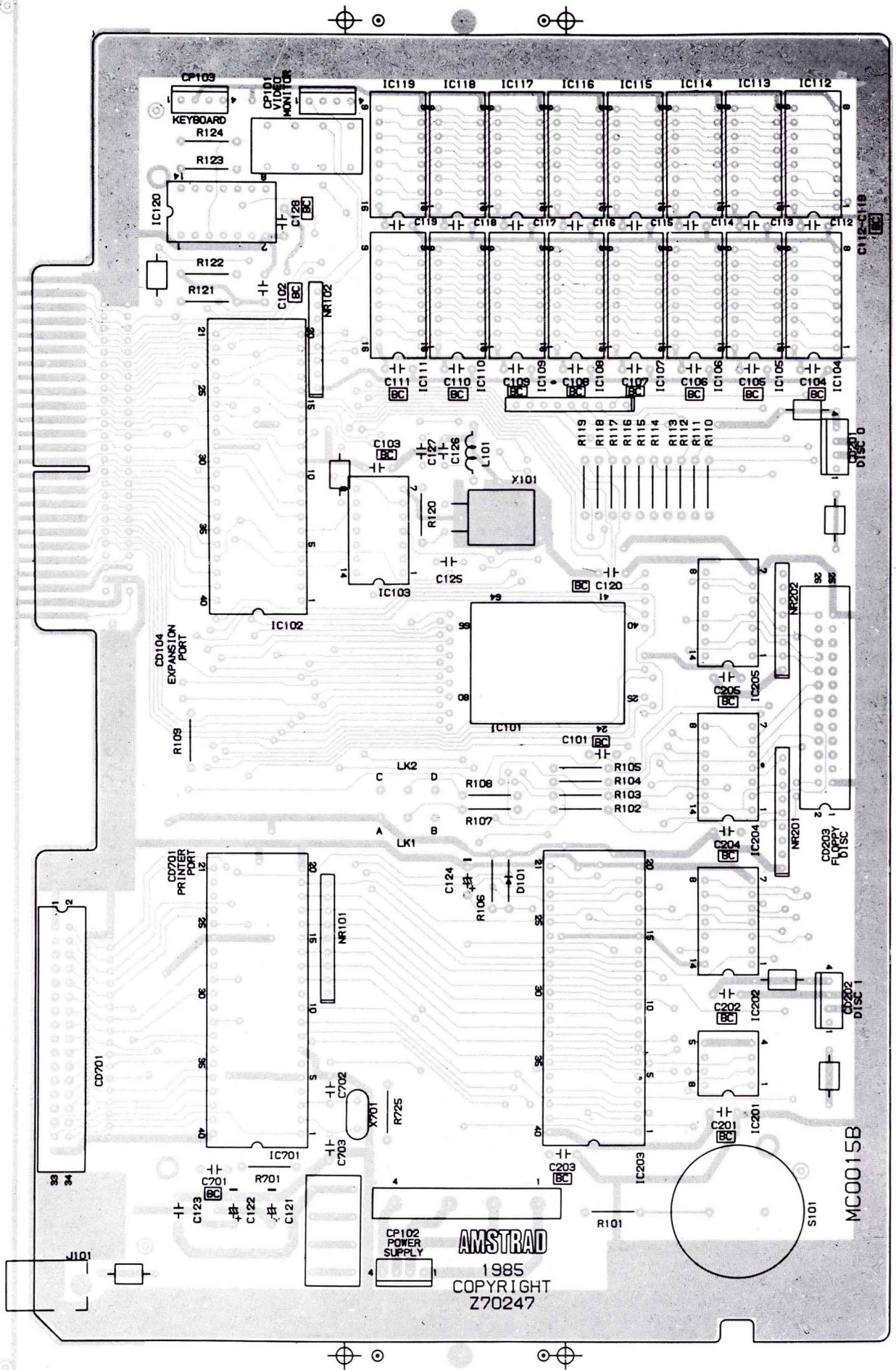



CPU P.C.B.

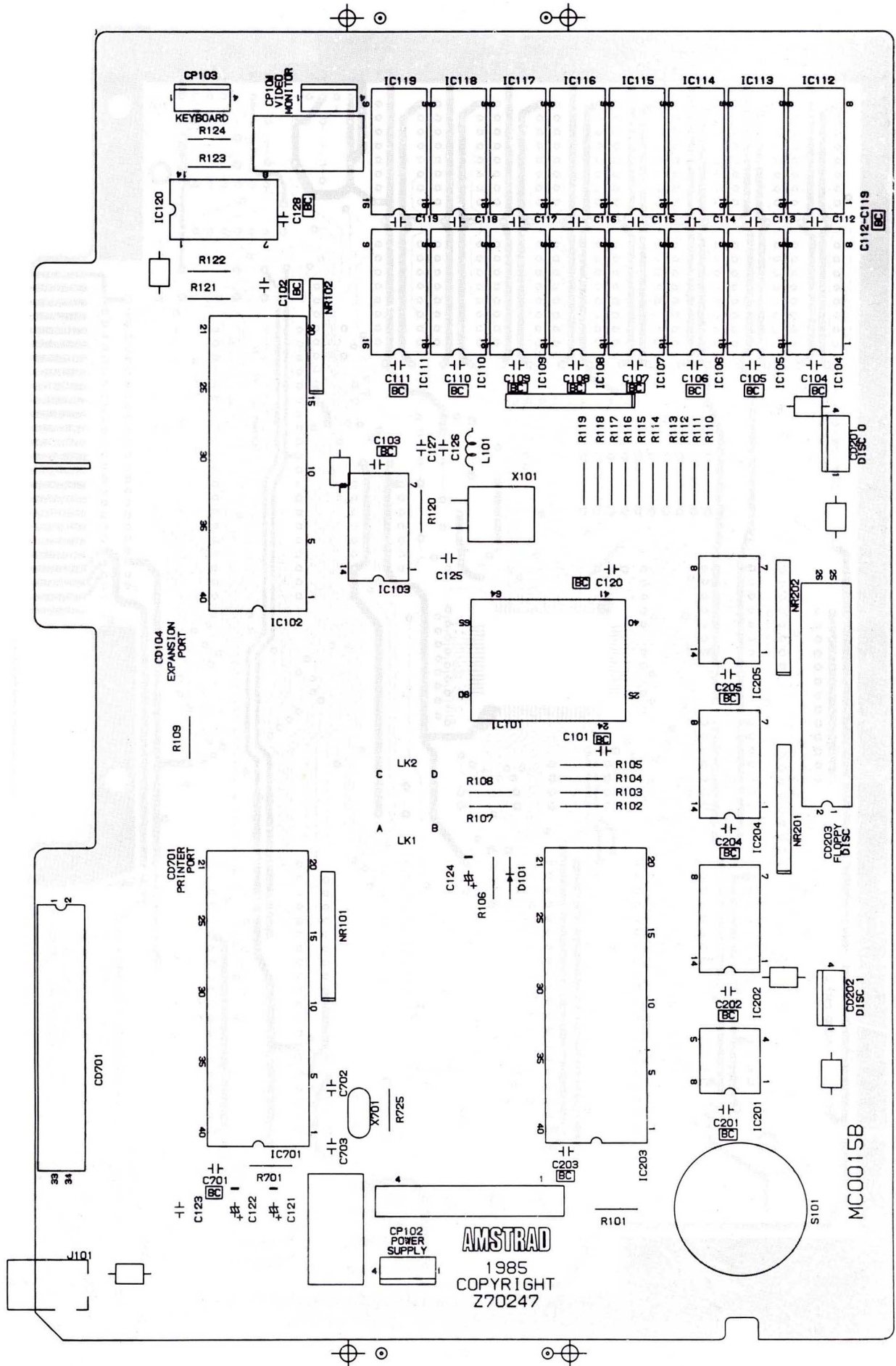

AMSTRAD  
1985  
COPYRIGHT  
Z70247

# CPU PCB MkII

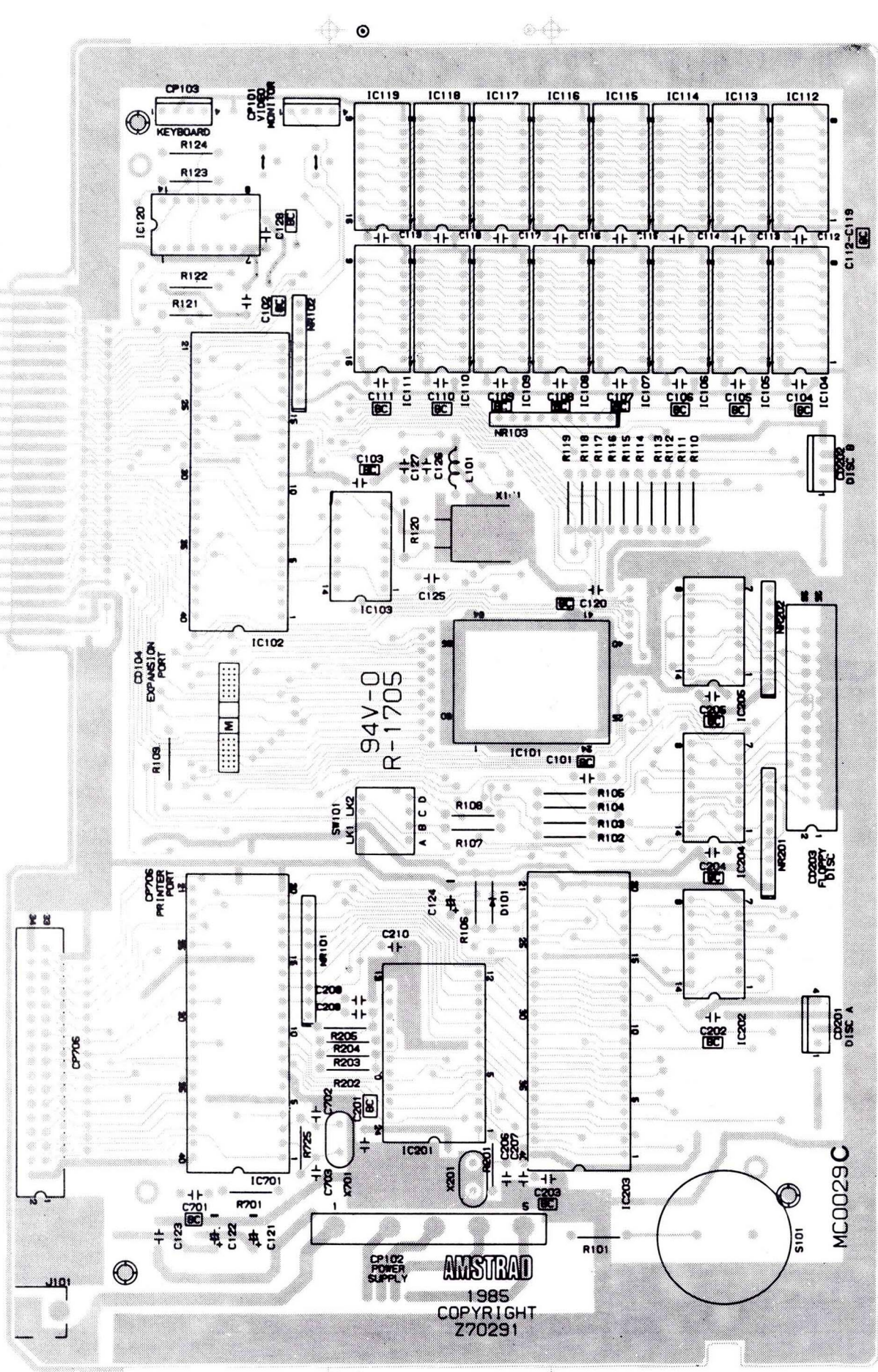

# CPU PCB MkII

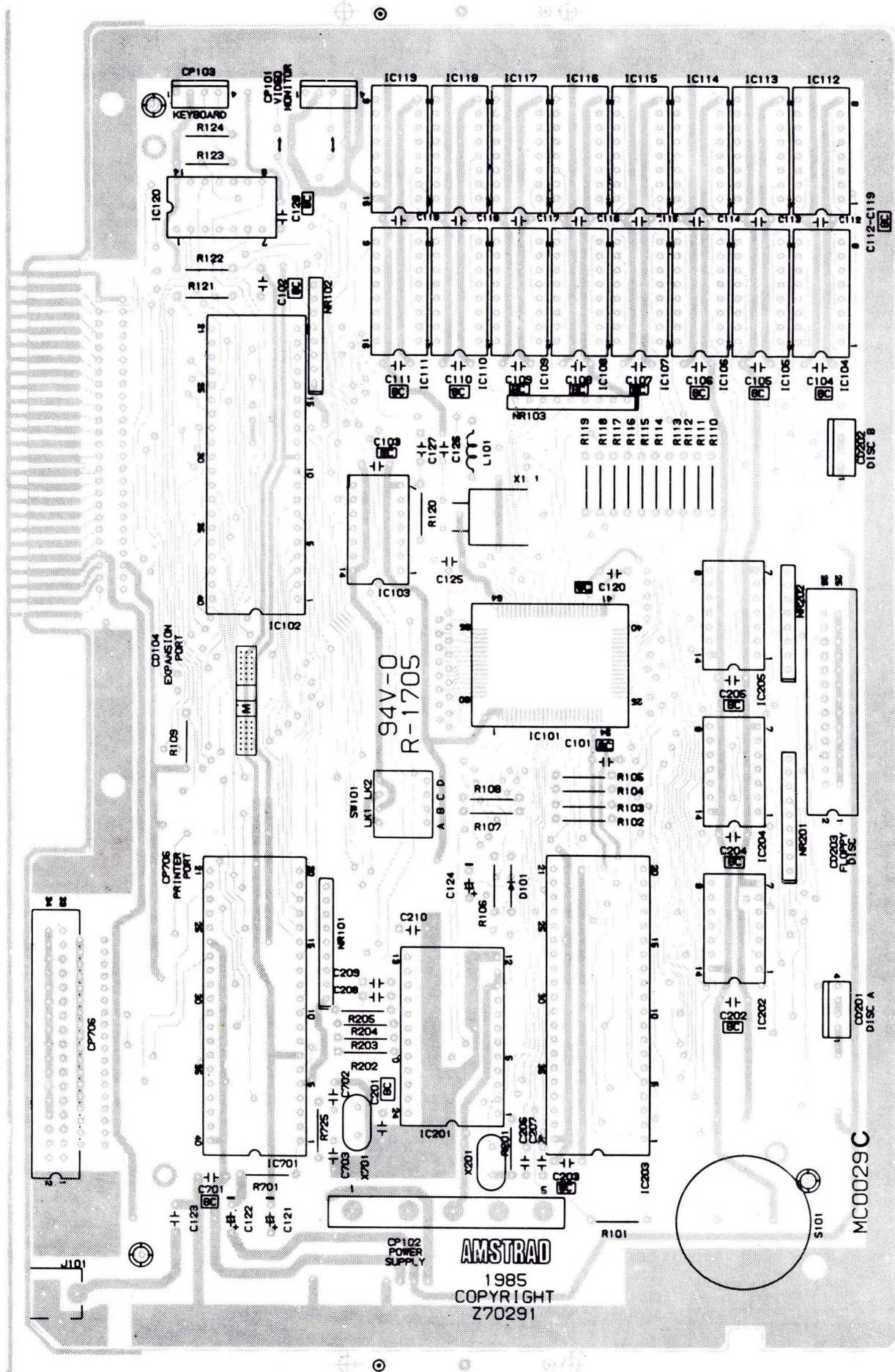

# PCW8256 PRINTER MECHANICAL PARTS LIST

PRINTER

Starred parts are for PCW8512 only.

Ref	Description	Part No.
1	Paper Tray	171121
2	Dust Cover	171122
*2	Dust Cover	171234
3	Paper Holder	171123
4	Cabinet Top	171124
*4	Cabinet Top	171220
5	Paper Loading Knob	171125
6	Paper Feed Knob	171126
7	Printer Mechanical Assy.	171127
8	Cord D.C. 1A560403	171128
9	Bottom Cabinet Assy.	171129
*9	Cabinet Bottom	171221
10	Cord Connector Printer	171130
11	Reduction Gear	171141
12	Collar	171142
13	Traction Unit	171143
14	Bearing	171144
15	Tractor Ring	171145
16	Guide Pillar	171146
17	Pin Feed Roller	171147
18	Frame Tractor Feed	171148
19	Gear Transfer	171149
20	Adaptor Tractor Unit	171150
21	Bearing Platen	171151
22	Spring Compensation	171152
23	Gear Platen	171153
24	Gear Compensation	171154
25	Platen	171155
26	Bracket Platen Retainer	171156
27	Roller Paper Guide	171157
28	Holder Roller Paper Guide	171158
29	Bearing Support Rod	171159
30	Paper Guide	171160
31	Paper Guide Assy.	171161
32	Arm Paper Guide	171162
33	Sensor Harness	171163
34	Clutch Assy. (L)	171164
35	Cluth Assy. (R)	171165
36	Motor Paper Feed	171166
37	Motor Head Drive	171167
38	Bracket Head Motor	171168
39	Reduction Gear	171169
40	Gear A	171170
41	Bracket Gear	171171
42	Gear Main	171172
43	Gear B	171173
44	Gear Ribbon Drive	171174
45	Bracket Print Head Guide Rod	171175
46	Circlip	171176
47	Bracket Timing Belt	171201
48	Printer Chassis	171184
49	Metal Washer	171177
50	Rubber Gromet	171178
51	Gear C	171179
52	Home Sensor	171180
53	Harness Print Head	171181
54	Spring Paper Tension	171182
55	Micro Switch Bail Bar	171183
56	Paper Sensor	171184
57	Clamp Print Head Flex Connector	171185
58	Print Head Assy.	171186
59	Bail Bar Arm Left	171187
60	Spring Bail Bar	171188
61	Bail Bar End Roller	171189
62	Collar Bail Bar	171190
63	Bail Bar Mid Roller	171191
64	Carriage Print Head Bail Bar	171192
65	Bail Bar	171193
66	Connecting Arm Bail Bar	171194
67	Sprocket Timing Belt (R)	171195
68	Guide Pillar (A)	171196
69	Guide Pillar (B)	171197
70	Bail Bar Arm Right	171198
71	Bail Bar Arm Connector	171199
72	Head.Pressure Adjuster	171200
73	Sprocket Timing (L)	171202
74	Washer	171203
75	Belt Timing	171204
76	Bracket Main Timing Belt	171205
77	Cover Gear	171206
78	Tractor Feed Assy.	171211

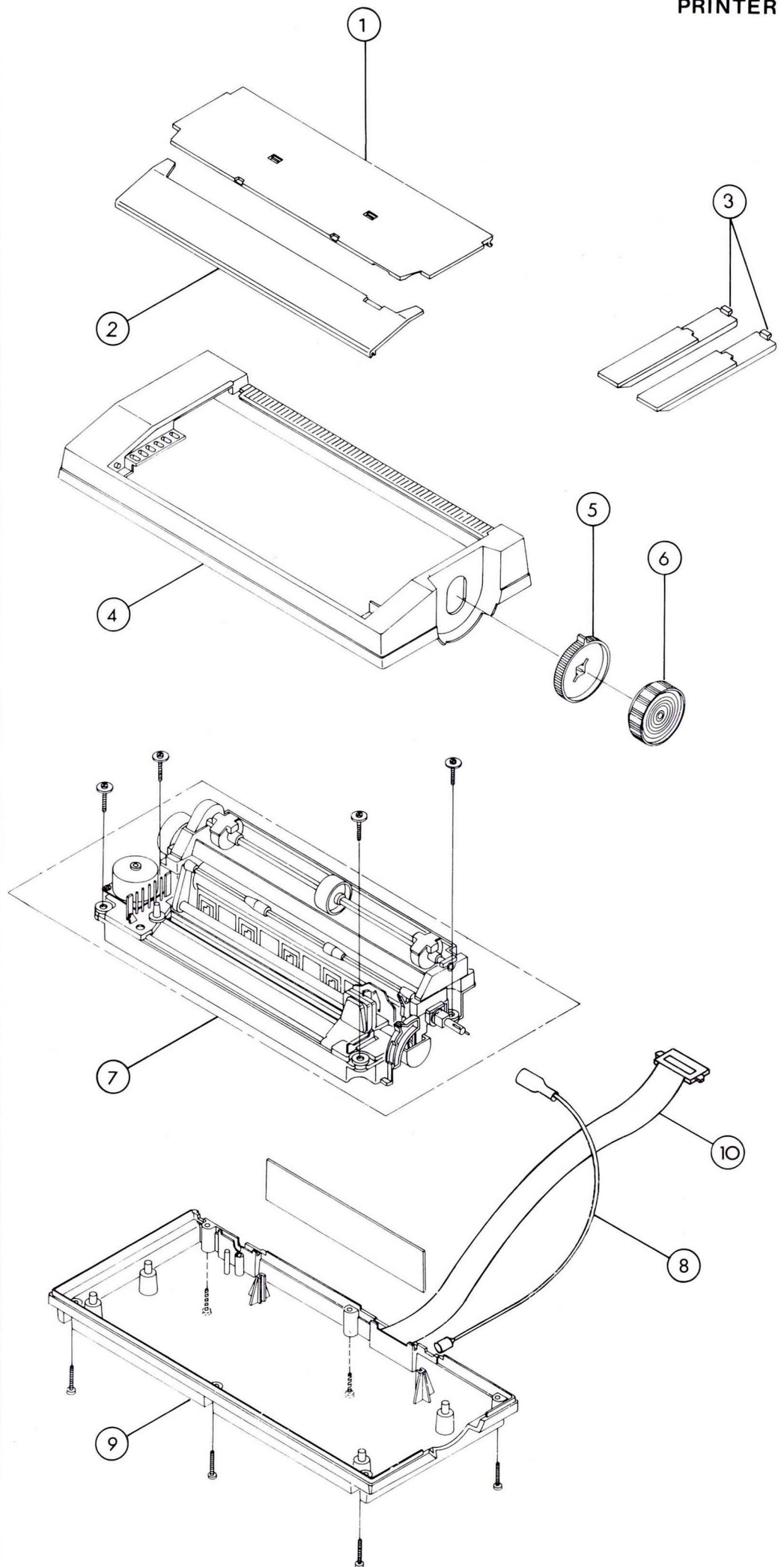

# EXPLODED DRAWING

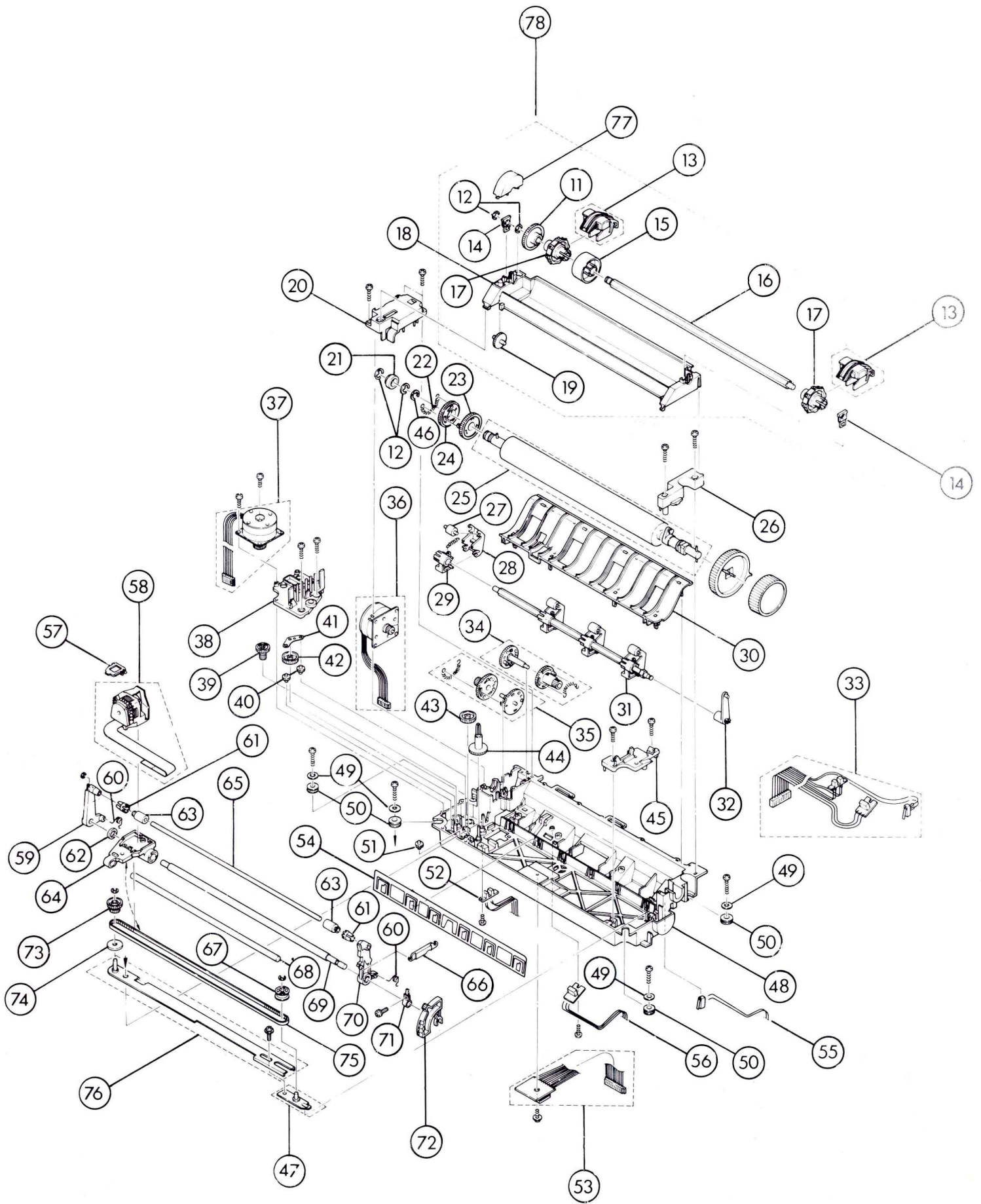

Note : 8 - 11 is set inside the carrier ( 8 - 10 ).

The whole mechanism (symbol 7) is available as an exchange part from Amstrad PLC



**MONITOR/KEYBOARD ELECTRICAL PARTS LIST**

Circ Ref.	Description	Part No.
<b>I.C.s</b>		
IC101	Amstrad 40028	171031
IC102	Z8400AP	40080
IC103	TC74HCU04P	40008/A
TC104-111	TMM41257P-15	171032
IC120	TC74HC14P	171033
IC201	SED9420CAC	171034
IC202, 2001	TC74HC00	171035
IC203	UPD765AC-2	40018
IC204,205	TC74HC04	171037
IC701	Amstrad 40026	171038
IC4001	LA1385	171039
IC4002	AN5753	171040
IC5001	STK7308	170445
IC5002, 5003	AN6531	171041
IC5004	AN78N24	171042
IC801	Amstrad 40027	171043
<b>Transistors</b>		
Q2001	KTC950Y	170448
Q4001, 5006, 5008, 5011, 5013	KTC1815Y	170447
Q4002	2SD1159	171044
Q5001	2SD1207	170451
Q5002-5004	2SD1666	171045
Q5005, 5007, 5009, 5010, 5012	KTA1015Y	170453
Q8001	KTC2229Y	171046
<b>Diodes</b>		
D101, 801	1S2472-HS	170455
D2001, 4001, 5012	DS442X-BT	1422117
D2002	GZA2.0 X BT	171047
D4002	V09C	170629
D4003	V06C	170630
D4004	BB-4	1422116
D4005	11E2TA1	171049
D4006	11E1TA1-T	171050
D5001-5004	20E10	171048
D5005, 5007	RD3.6FB	171458
D5006, 5008	DFC10E-KB4	171051
D5009, 5011	30DF2-FC	171052
D5010	30DF2	171053
D8001	MA2560	171054
<b>Coils</b>		
L101	Coil LAL03KH2R2M	171055
L4001	Coil 100uH 1451MM	1400148
L4002	Coil Linearity 21000006	170631
L5001	Coil Filter AC FKOB160MH14	1400130
L801	Coil LAL 03KH470K	171119
T4001	Tx. Horizontal Drive RB-20852	170633
T5001	Tx. Switching 8140001	171056
<b>Jacks, Switches, Potentiometers</b>		
J101	Jack DC HEC)470-630	170024
J102	IC Socket 20 Pin Duel in line	170121
J103-118	IC Socket 8 Pin Duel in line	170119
J801	4 Pin DIN Socket	171009
	TCS4440-01-1011	
J8001	CRT Socket I CS-B103	171022
SW5001	Push Switch Power On/Off ESB-90197S	S/171013
VR2001	Brightness Control 500 ohm	171006
VR4001	V. Hold Control	171024
VR4002	10k SF EVN-52JA00B14	171105
VR4003	2k SF EVN-52JA00B23	171106
VR4004	100k SF EVN-52JA00B15	171107
VR4005	500 ohm SF EVL-V0AA00B52	171108
VR5001	1k SF EVN-52JA00B13	171109
VR5002	5k SF EVN-52JA00B53	171110

Circ Ref.	Description	Part No.
<b>PCB's</b>		
PCB001	MM0010B	171111
PCB002	MS0027B	171112
PCB003	MS0028B	171113
PCB004	MS0029B	171114
PCB101	MC0015Q	171017
PCB801	MK0001A	171115
<b>Miscellaneous</b>		
CFD101	EBFCF2SS1N05	171116
CFD102	EBFCF2SS1005	171117
F5001	2A (T) 250V	1400253
ICP501-503	ICP-N75	171057
NR101, 103, 201	RM 8-103J	171058
NR102	RM 7-103J	171059
NR103	RM 7-681J	171060
S101	EFB-RD24C01B (8256)	171061
S101	EFB-RD24C01B (8512)	171225
TH4001	STD 100	171062
X101	Crystal Oscillator NR-18 32.0MHz	171063
X701	Ceramic Oscillator	171064
X801	Ceramic Oscillator KBR-5.0M	171232
X201	Ceramic Oscillator CSA 16.00 MX7	171231
NR801	RM 8-223J	171118
CD803	DIN Cord (Keyboard)	171028
<b>Resistors 1/4Watt Carbon Film</b>		
Value	Circuit Reference	Part No.
33ohm	R102-105, 110-116, 118, 119	10019
39ohm	R4002	10018
82ohm	R117	10031
150ohm	R4027	10036
390ohm	R8004	10046
470ohm	R805-808, 5008, 5010	10048
560ohm	R101	10050
680ohm	R109, 2004	10052
1k	R2001, 4011, 4018, 4026, 5015-5017, 5019, 5023, 5026-5028, 8005	10061
1k5ohm	R8003	10065
2k2ohm	R121, 4014, 5021	10069
2k7ohm	R2003, 4005, 8001	10068
3k3ohm	R2002, 4012, 4025	10073
3k9ohm	R4003, 4004	10075
4k7ohm	R122, 803, 804, 5018	10077
5k6ohm	R2005, 2006	10079
8k2ohm	R4017	10083
10kohm	R106-108, 801, 802, 809, 4007, 4020, 5032	10085
12kohm	R4001, 5024	10087
22kohm	R4008, 4010, 4019	10093
27kohm	R4013	10095
33kohm	R8006, 8007	10097
39kohm	R4006	10099
47kohm	R701	10101
56kohm	R4021	10103
100kohm	R123, 124	10109
270kohm	R5004	10119
470kohm	R4024	10145
1Mohm	R120, 725, 810	10147
10Mohm	R4023	171065
<b>Resistors 1/2Watt Carbon Film</b>		
8ohm2	R5022	171066
68ohm	R5029, 5030	171067
1kohm	R5014, 5025	1400165
180kohm	R5006, 5007	171068
<b>Parts List Mark II version</b>		
L500	Coil Filter A.C. PAL 1021C	171226
T5001	Transformer Switching	171227
VR4001	V. Hold Control EVJEHAE30B34	171228
X801	Ceramic Oscillator KBR-5.0M	171232
X201	Ceramic Oscillator GSA 16.00MX7	171231

## ELECTRICAL PARTS LIST

Value	Circuit Reference	Part No.
<b>Resistors Metal Oxide</b>		
1ohm/1W	R4009	171069
1kohm/1W	R5003	171070
0.27ohm/2W	R5012	171071
0.33ohm/2W	R5013	171072
10ohm/2W	R4016	171073
33ohm/2W	R5009	171074
330ohm/2W	R5020, 5031	171075
4k7ohm/2W	R8002	171076
1ohm/3W	R5002	171077
5ohm6/5W	R5001	1422137
<b>Fuse Resistors</b>		
15ohm/¼W	R5011	171078
22ohm/½W	R4022	171079
39ohm/¼W	R4015	171080
<b>Ceramic Capacitors</b>		
12pF	C4018	809251
30pF	C8002	24029
100pF	C4003	1422144
2200pF/4kV	C5013	171081
0.001uF/500V	C5014-5016, 8003	171082
0.001uF/2kV	C5011	1422147
0.015uF/2kV	C5010	171083
0.0022uF/2kV	C5002-5004	1400223
0.0047uF	C4024, 5008	170600
0.01uF	C127	1400215
0.047uF	C5009	24015
0.1uF/16V	C101-120, 128, 201-205, 701, 804, 5029	171084
0.1uF/50V	C123	171085
<b>Electrolytic Capacitors</b>		
0.33uF/50V	C5028	171086
0.47uF/50V	C4001	150909
1uF/50V	C803	20062
1uF/160V	C4029	1422151
1uF/250V	C5006	1400152
4.7uF/50V	C4006, 4020	1400240
10uF/16V	C122, 4010, 4015	20024
10uF/25V	C4032	20037
10uF/50V	C2001, 5020-5023	1400242
10uF/160V	C4030	170608
22uF/16V	C4008	20025
22uF/63V	C8001	170609
33uF/10V	C4012	170610
33uF/50V	C5024	171087
47uF/10V	C121, 124, 805	1400244
47uF/50V	C4031	171088
100uF/16V	C2002	20028
100uF/50V	C5012	171089
100uF/400V	C5005	171090
220uF/10V	C4011	170611
220uF/16V	C4021, 4025, 4026, 4033	20029
220uF/35V	C5007	20055
470uF/10V	C5025	20031
470uF/16V	C5017, 5027	1400248
470uF/35V	C5018, 5026	171091
470uF/50V	C5019	171092
1000uF/10V	C4014	800372
<b>Polycarbonate Capacitors</b>		
0.001uF/50V	C4019	171093
0.0012uF/50V	C4022	171094
0.0047uF/50V	C4023	170437
0.015uF/50V	C4016	171095
0.018uF/50V	C4017	171096
0.027uF/50V	C4002	171097
0.047uF/50V	C4004, 4005, 4013	170422
<b>Polypropylene Capacitors</b>		
0.0027uF/400V	C4028	171098
0.047uF/400V	C4027	171099
<b>Tantalum Capacitors</b>		
1uF/50V	C4007	171100
10uF/16V	C4009	1422167
<b>Non Polarised Capacitors Ceramic</b>		
33pF/50V	C702, 703, 801, 802	171101
<b>Special Types</b>		
0.1uF/250V	C5001	171102

## PCW 8512

List for parts different to PCW 8256

Value	Circuit Reference	Part No.
<b>Resistors</b>		
1kohm	R726	10061
1.5kohm	R204	10065
6.8kohm	R205	10081
33kohm	R203	10097
68kohm	R202	10105
1Mohm	R201	10147
<b>Ceramic Capacitors</b>		
7pF NPO	C206, 207	171235
<b>Poly Capacitors</b>		
0.001uF	C208	171093
0.01uF	C209	171236
0.047uF	C210	170422
<b>Metal Poly Capacitors</b>		
0.01uF/250VAC	C4034	171237
<b>IC's</b>		
IC112-119	IC TMM41257P-15	171032
<b>PCB's</b>		
PCB001	13MM0010C3	
PCB002	13MS0027C3	
PCB003	13MS0028C3	
PCB004	13MS0029C3	
PCB101	13MC0029C1	171017/A
PCB701	13MS0030C1	
PCB8012	13MK0001B3	

## PRINTER ELECTRICAL PARTS LIST

Circuit Ref.	Description	Part No.
<b>Miscellaneous</b>		
IC702	I.C. NE556CN	171131
IC703, 704	I.C. CD4503BC	171132
IC705	I.C. CD40106BC	171133
IC706, 708	I.C. HA13408	171134
IC707	I.C. CD4094BCN	171135
Q701, 703	TR. KTA10130	171136
Q702	TR. 2SC1815Y-LB106	171137
PCB701	P.C.B. MS0030B	171138
NR701	R. Network RM 7-472J	171139
NR702	R. Network RM 8-472J	171140
<b>Resistors ¼W Carbon Film</b>		
100ohm	R704	10032
150ohm	R706, 710	10036
1kohm	R705, 718	10061
2k2ohm	R707	10069
4k7ohm	R722	10077
22kohm	R709, 712, 713	10093
27kohm	R711, 714	10095
68kohm	R702	10105
1Mohm	R708	10147
10Mohm	R703	171208
<b>Resistors Metal Oxide</b>		
15ohm/2W	R716, 721	170410
680ohm/1W	R717, 719	171209
1k/1W	R715, 720	170406
<b>Ceramic Capacitors</b>		
100pF	C711	24016
1000pF	C714	1400215
0.001uF	C706, 710, 722	24027
0.01uF	C709, 713	24011
0.1uF	C704, 707, 708, 712, 715-718, 721	24020
<b>Electrolytic Capacitors</b>		
47uF/10V	C719	20027
1000uF/35V	C720	171207
<b>Polycarbonate Capacitors</b>		
0.0068uF	C705	171210



# CHASSIS SCHEMATIC DIAGRAM

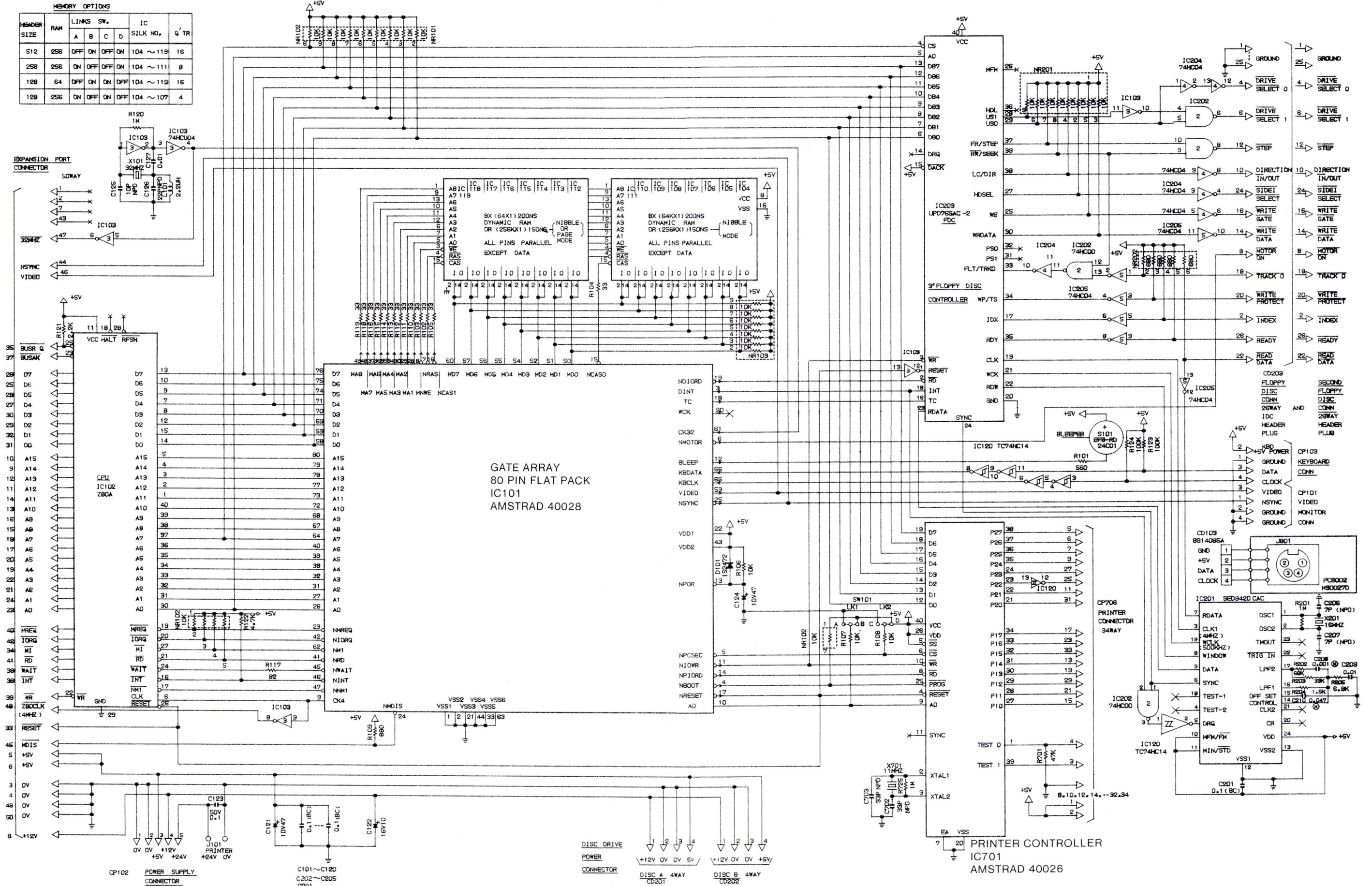

# PRINTER CIRCUIT DIAGRAM

